



HIGH QUALITY SCALE MODEL, RESIN MODEL

Hawker Demon

On entering service in 1930, Sydney Camm's Hawker Hart bomber proved so much quicker than the RAF's existing fighters that the potential for a fighter version of the newcomer was self-evident and developed without delay. Following initial evaluation of two prototypes at RAF Martlesham Heath, a batch of six Hart Fighters was duly completed in 1931 and placed for development with No.23 Squadron at RAF Kenley.

The adaptation was considered successful and in 1932 a contract was raised for the manufacture of an initial run of 17 such aircraft. At first the new aircraft was known as the Hart Fighter, being renamed the Demon in July 1932. The aircraft was ordered into full production, entering full service in 1933. In all 305 Demons were produced, 232 of them for the RAF.

Due to pressure of work at the H G Hawker Engineering Company, production of the last 59 Demons was subcontracted to Boulton-Paul Aircraft. In their time, Demons equipped six regular RAF and five Royal Auxiliary Air Force squadrons and saw service in the Abyssinia crisis of 1935.

As a fighter with the RAF the Demon was finally superseded from late 1938 by the Blenheim IF, but a few were used as target tugs until replaced by the Hawker Henley.

Operators: United Kingdom (RAF), Australia (RAAF)

TECHNICAL DATA

Engine:

- Rolls-Royce Kestrel IIS (485 HP)
- later Kestrel VDR (585 HP)

Max speed: 291 km/h at ceiling 3962 m

Weight (empty): 1513 kg

Range: 750 km

Wingspan: 11,35 m

Length: 9,02 m

Height: 3,35 m

Armament: twin forward firing 7.7 mm Vickers machine guns + one dorsal ring-mounted Lewis Mk.III gun + eight 20 lb bombs

Crew: two – pilot plus observer/gunner

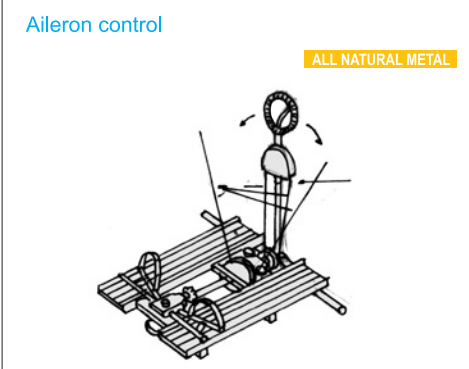
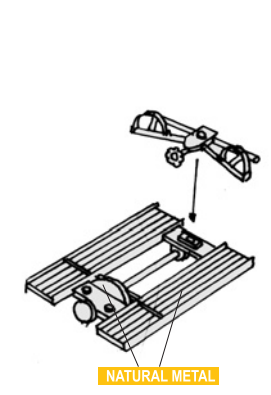
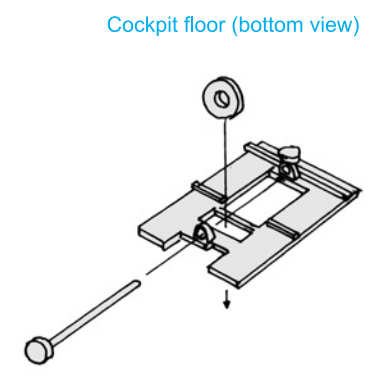
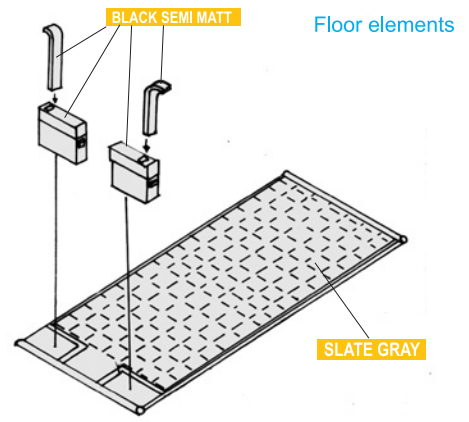
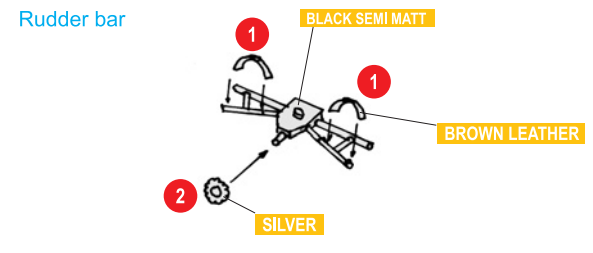
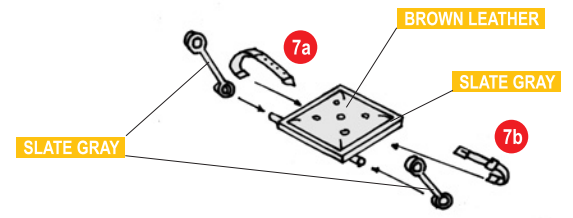
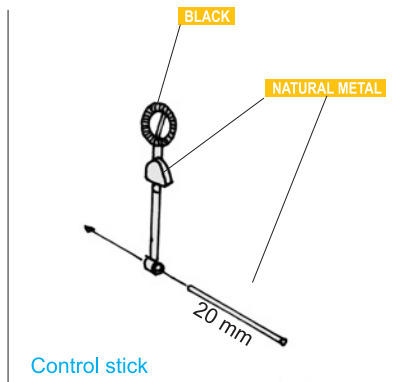
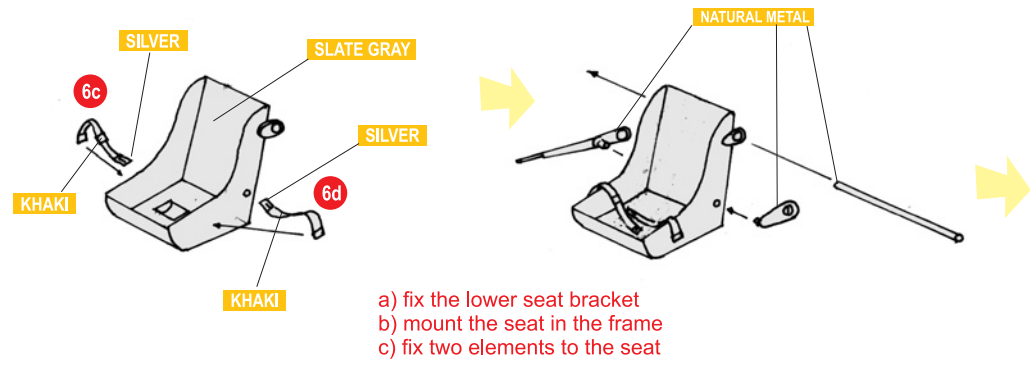

ALL NATURAL METAL

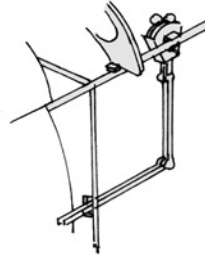
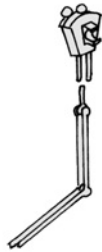
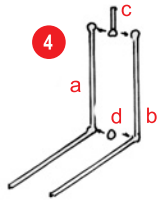

Engine control

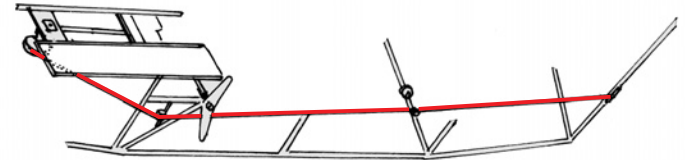

Rudder transmission scheme (on the frame)

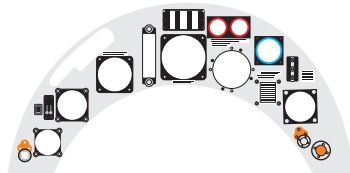
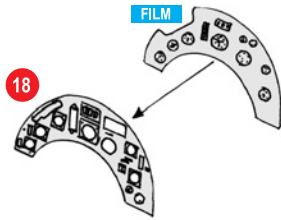

Control panel colours scheme

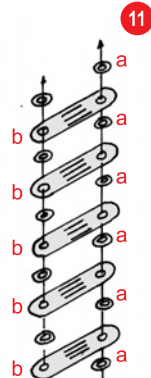

Prepare on your own

BLACK SEMI MATT

Compass placement in the frame

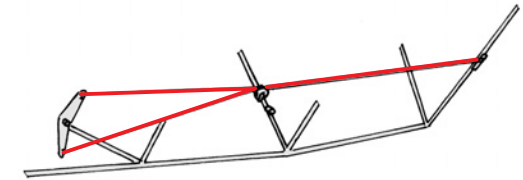
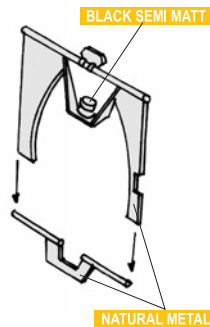

Elevator transmission scheme (on the frame)

BROWN LEATHER

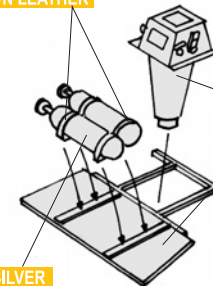

BLACK SEMI MATT

SILVER

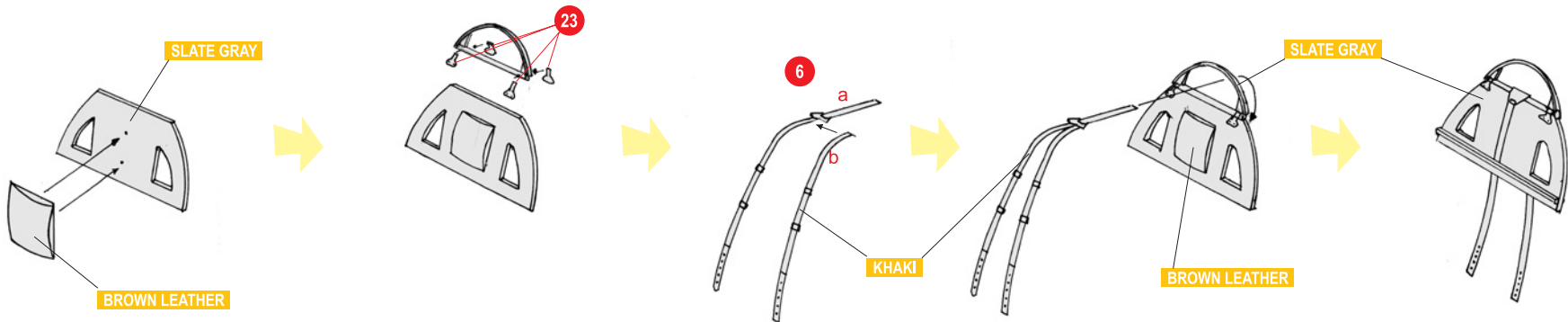
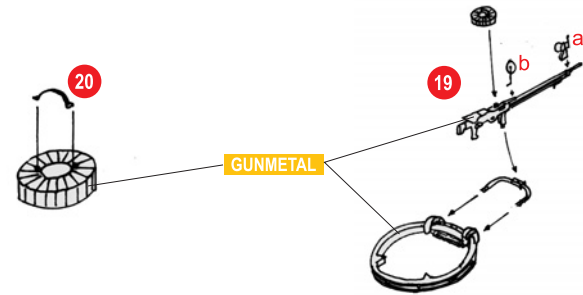
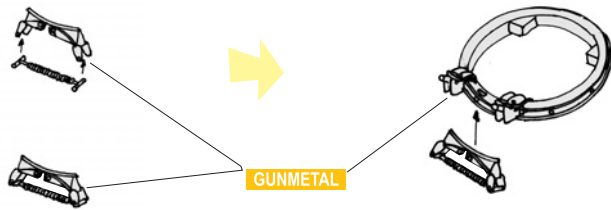
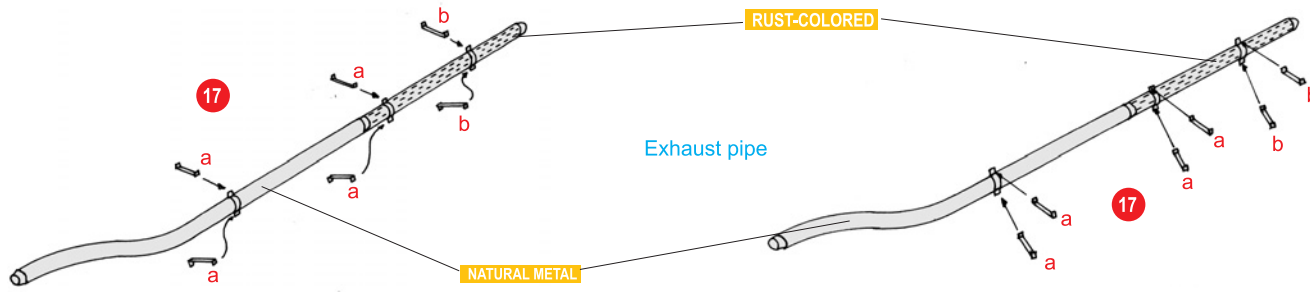

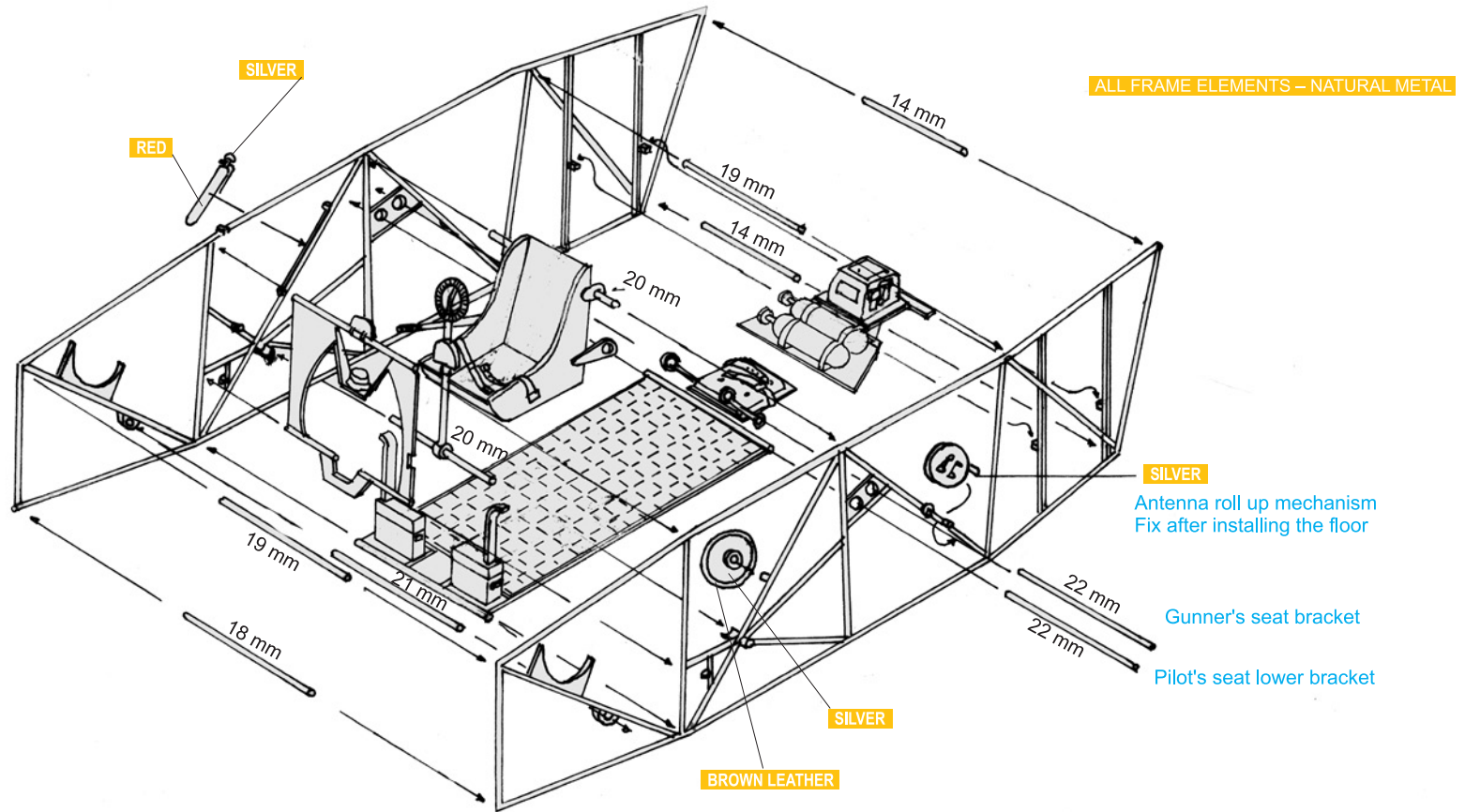

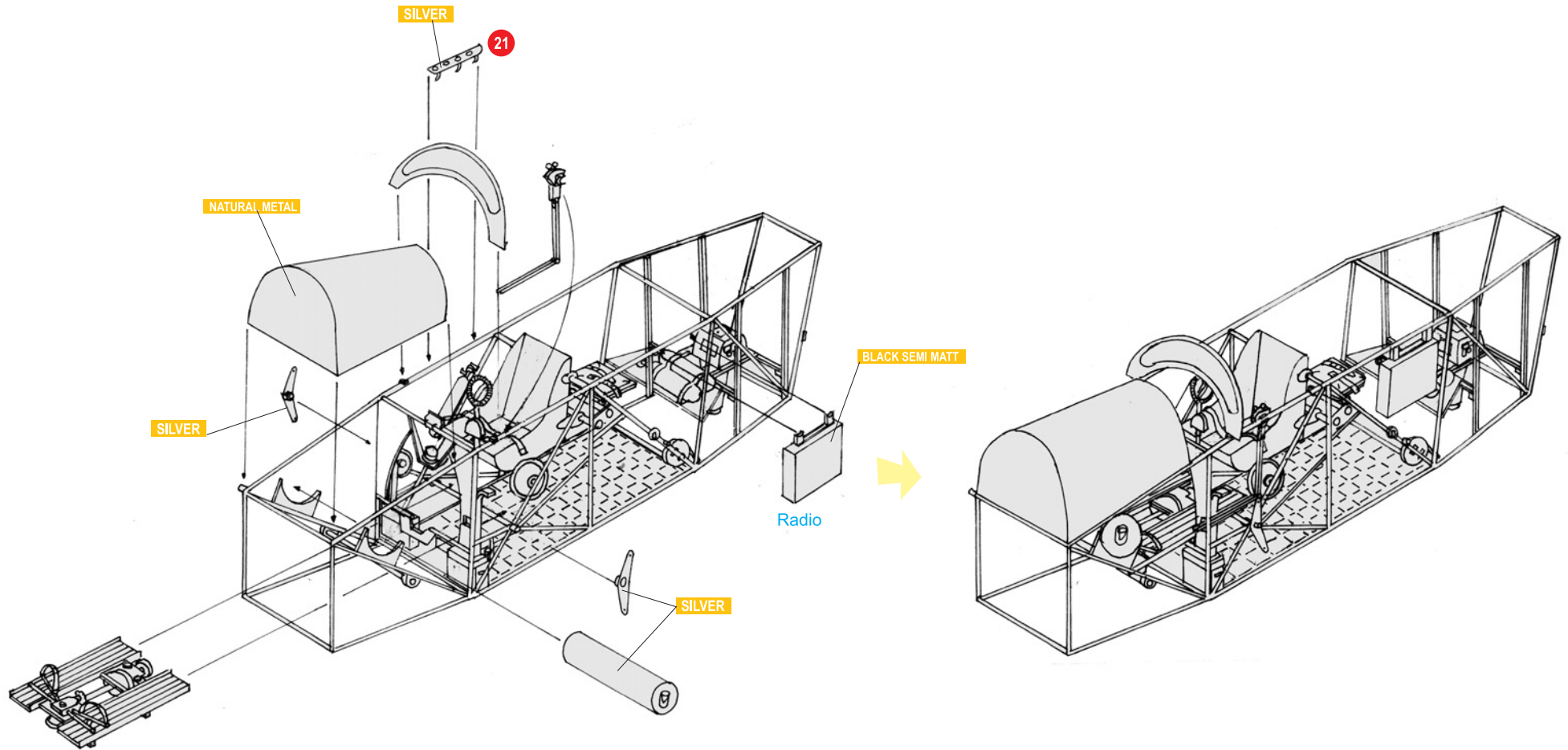

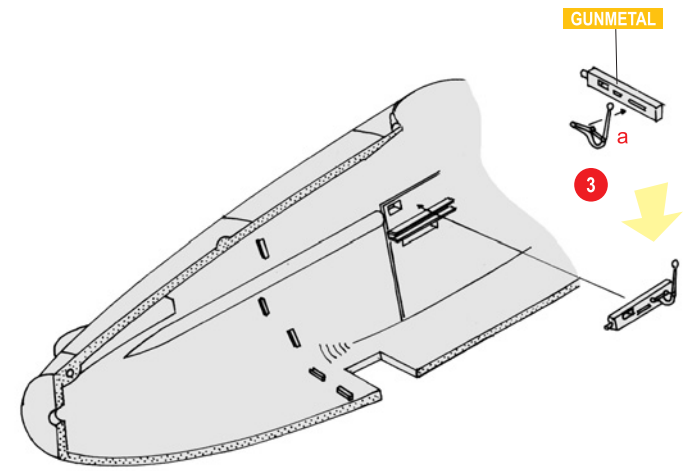
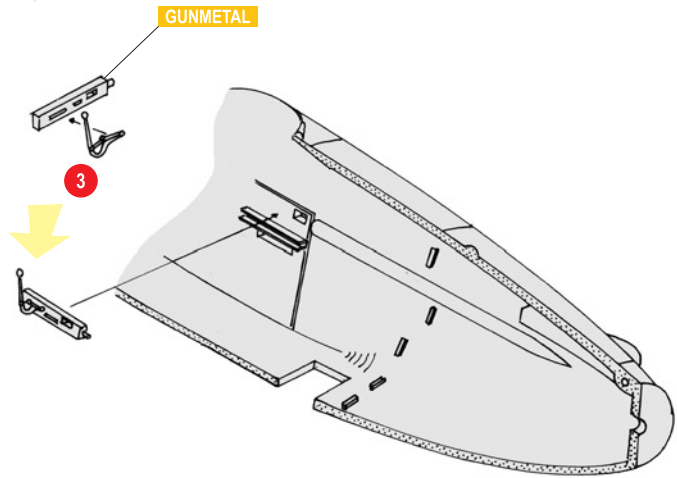
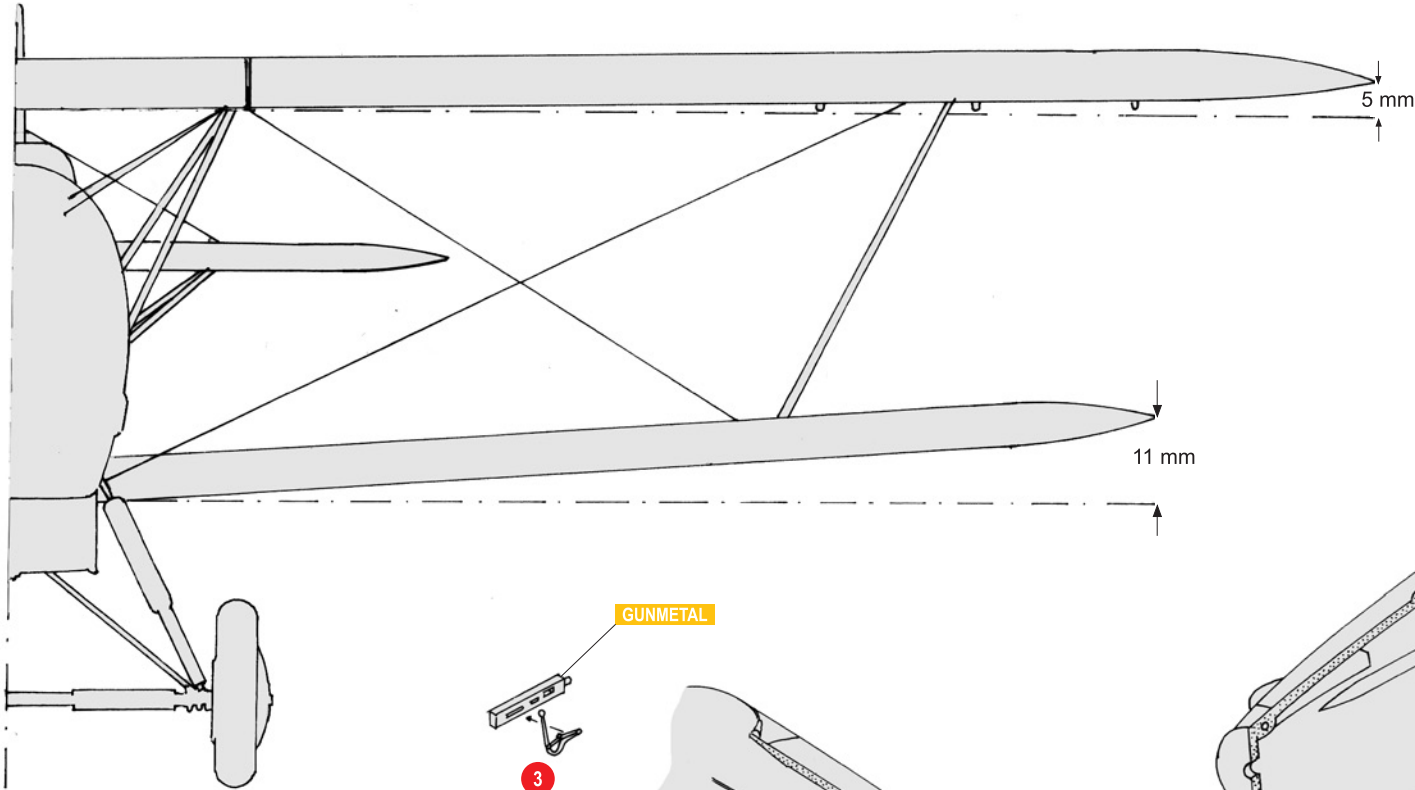

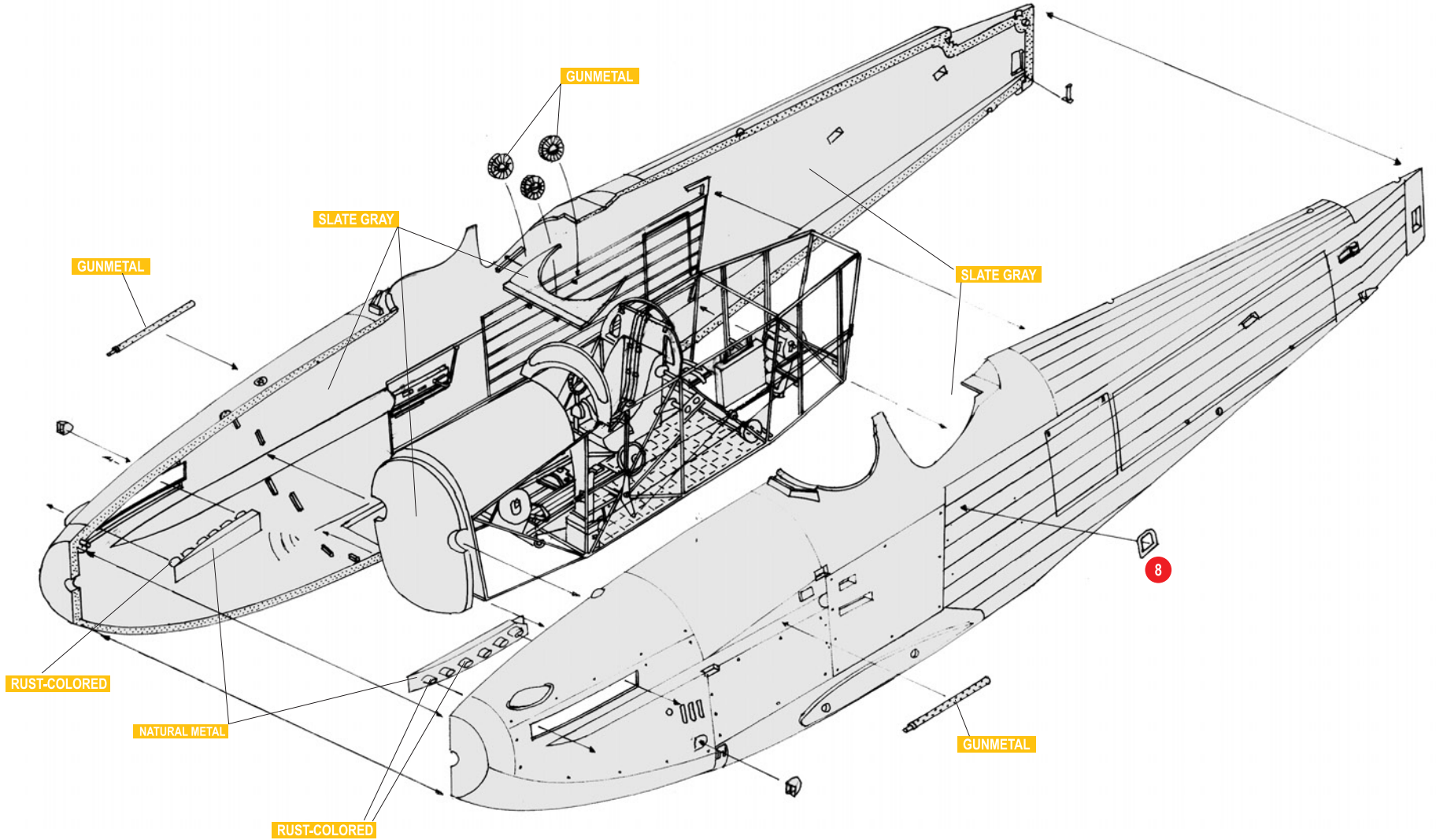

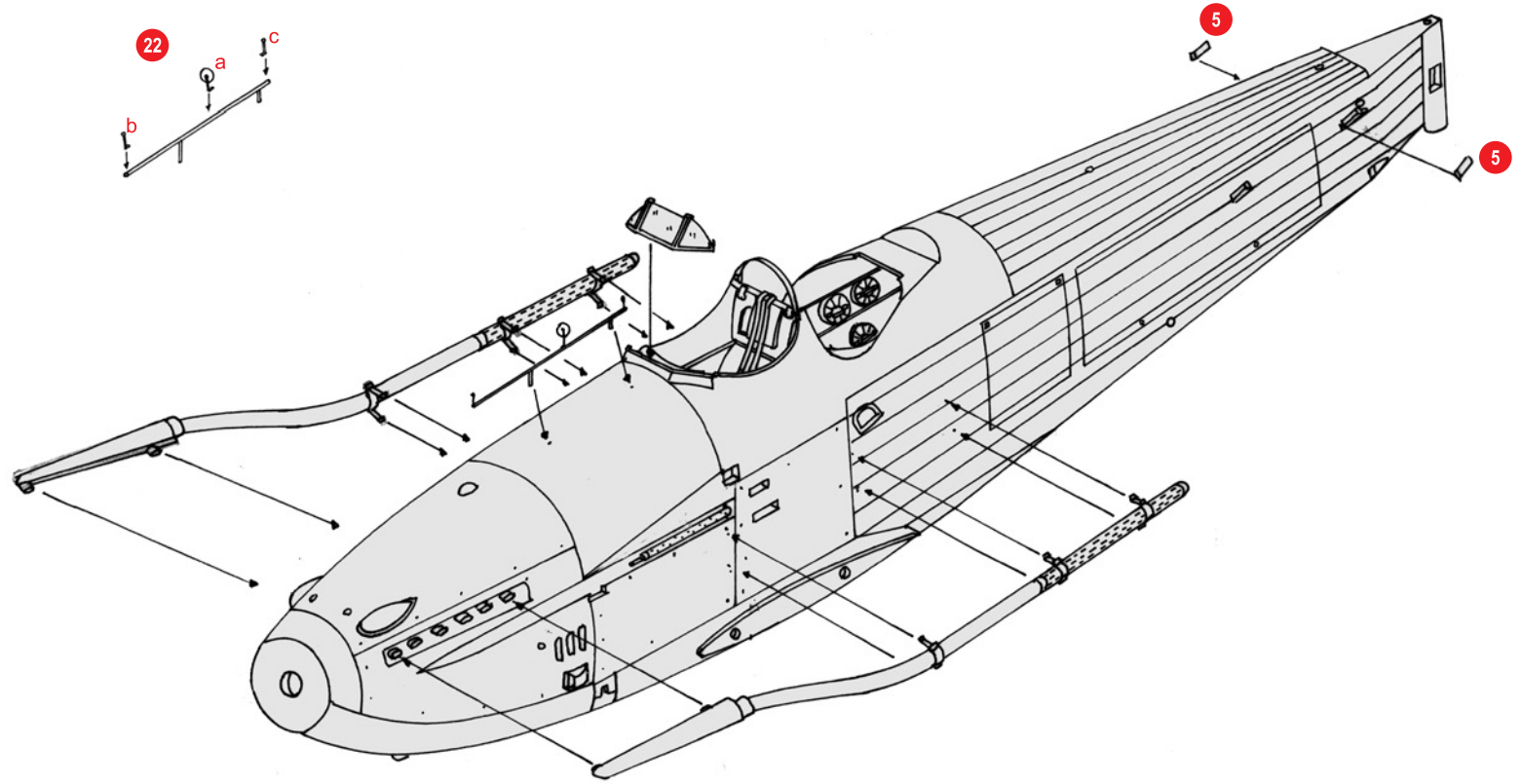

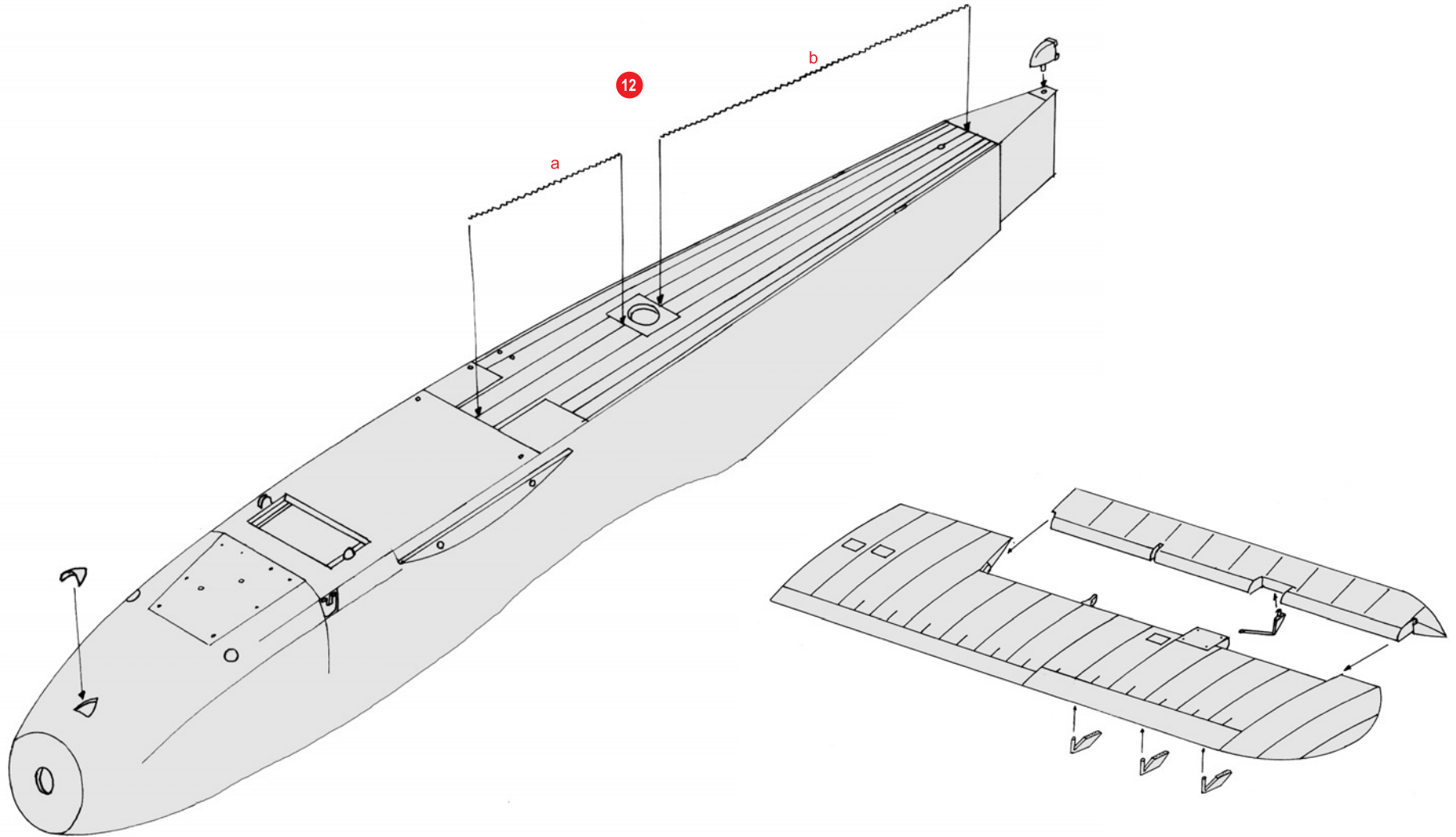

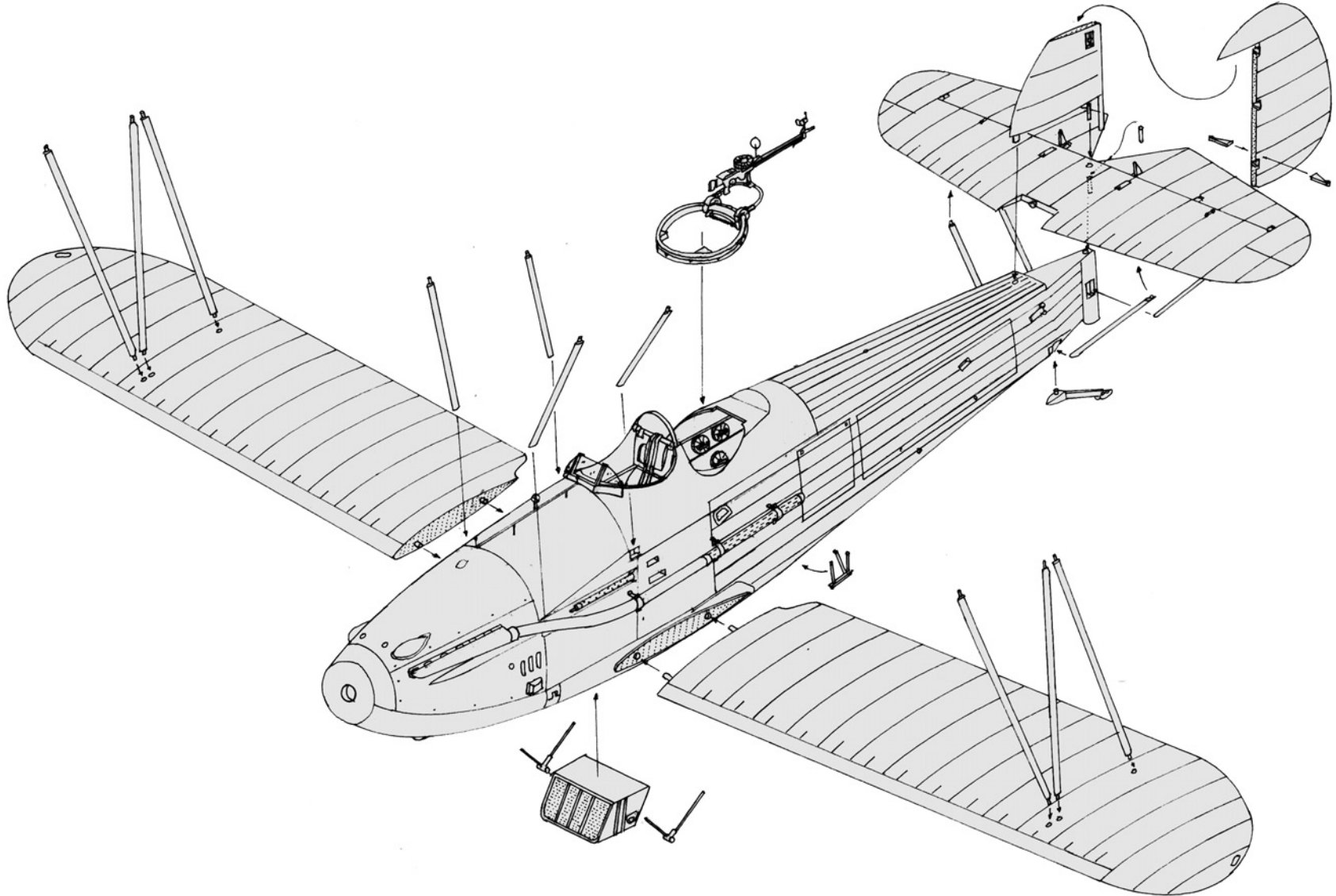

The upper surface of the centre section

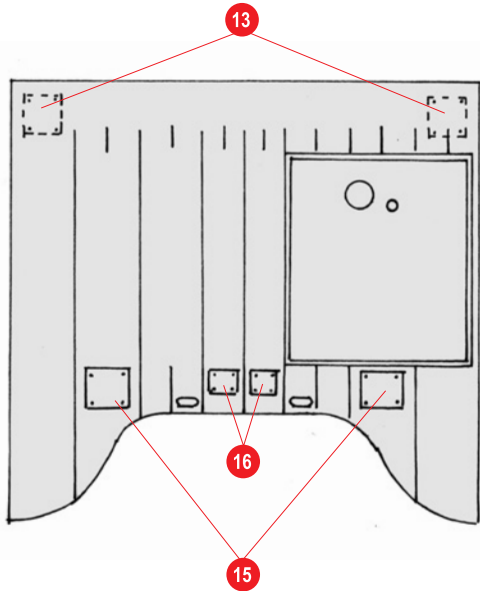

The upper surface of the upper wing

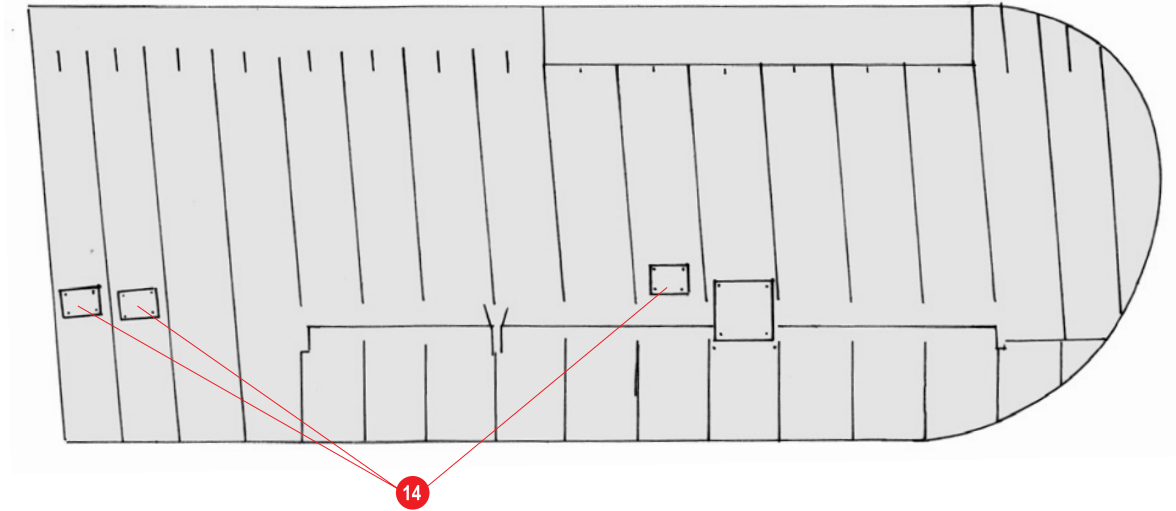

The upper surface of the lower wing

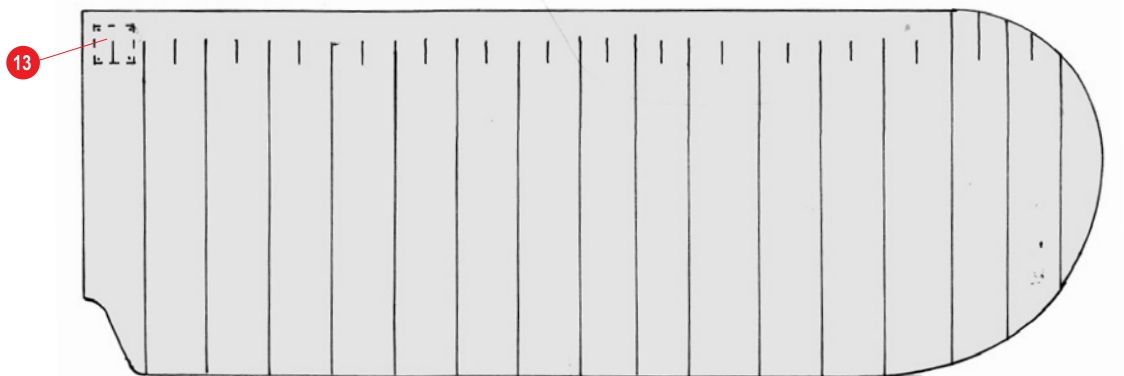

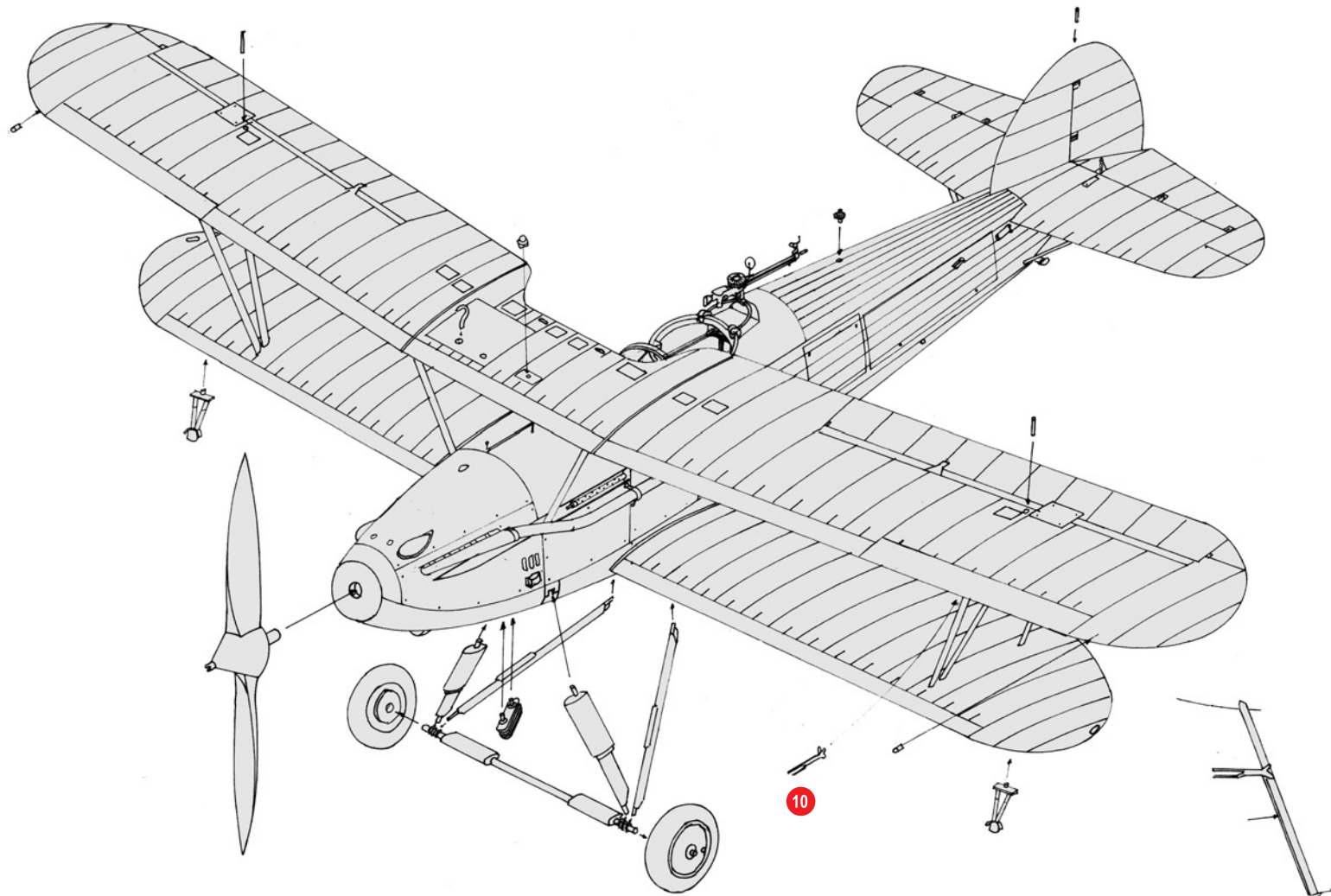

Bracing scheme

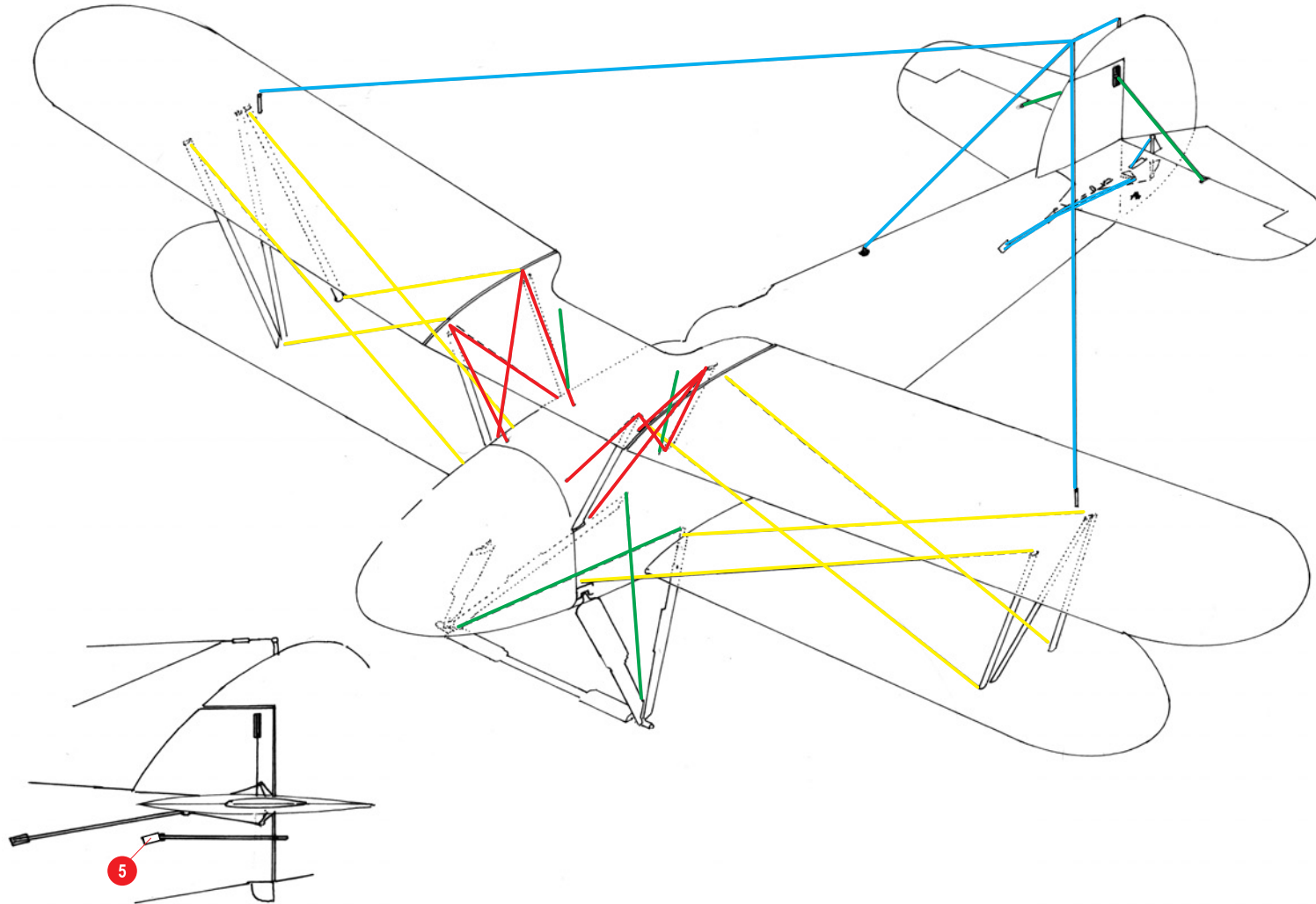

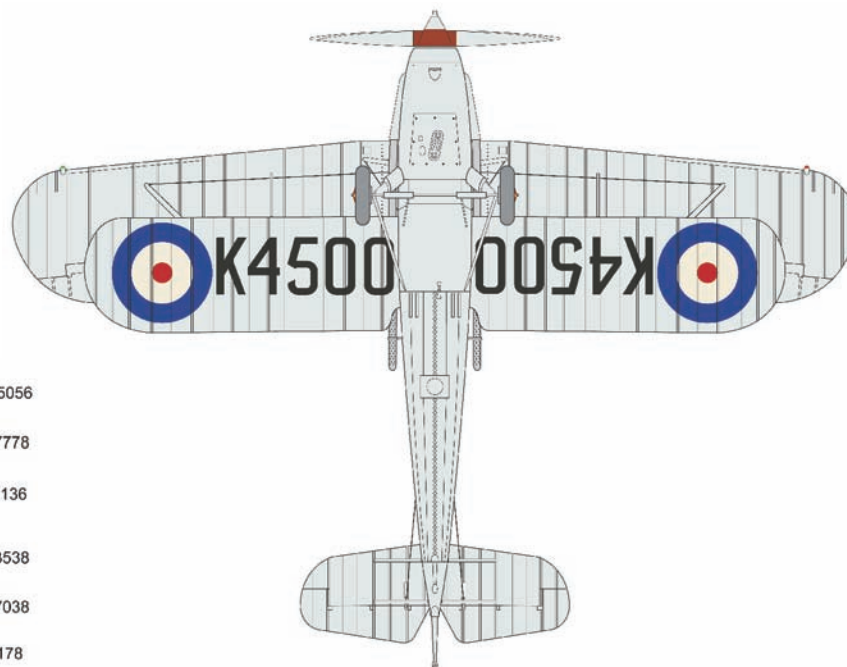
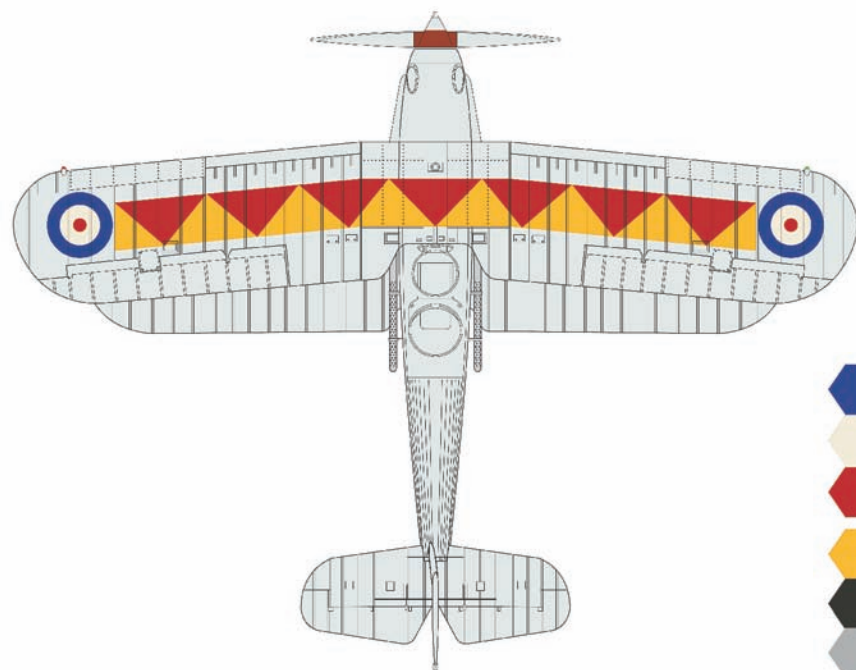

Hawker Demon, K4500
604 (Country of Middlesex) Squadron
Auxiliary Air Force, Hendon, 1936



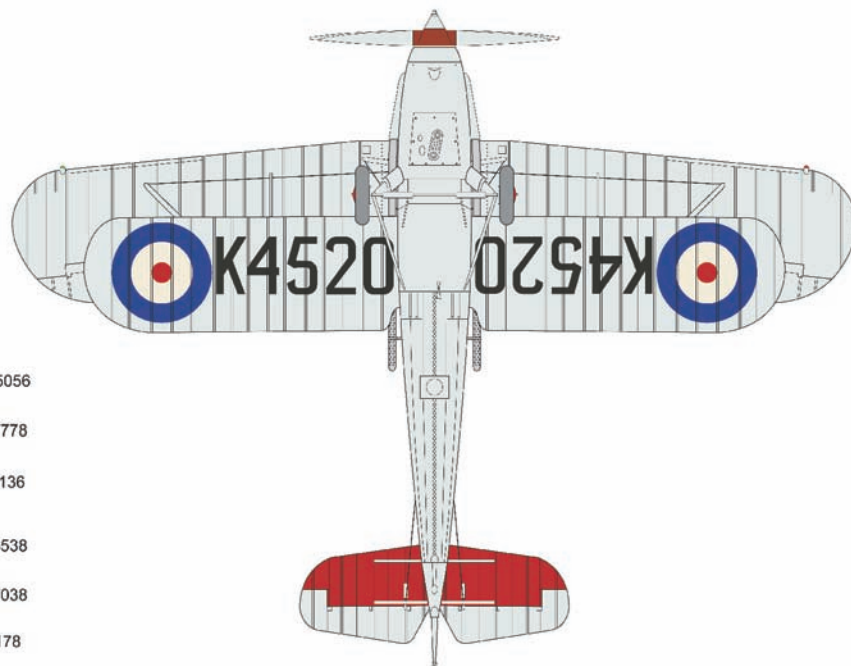
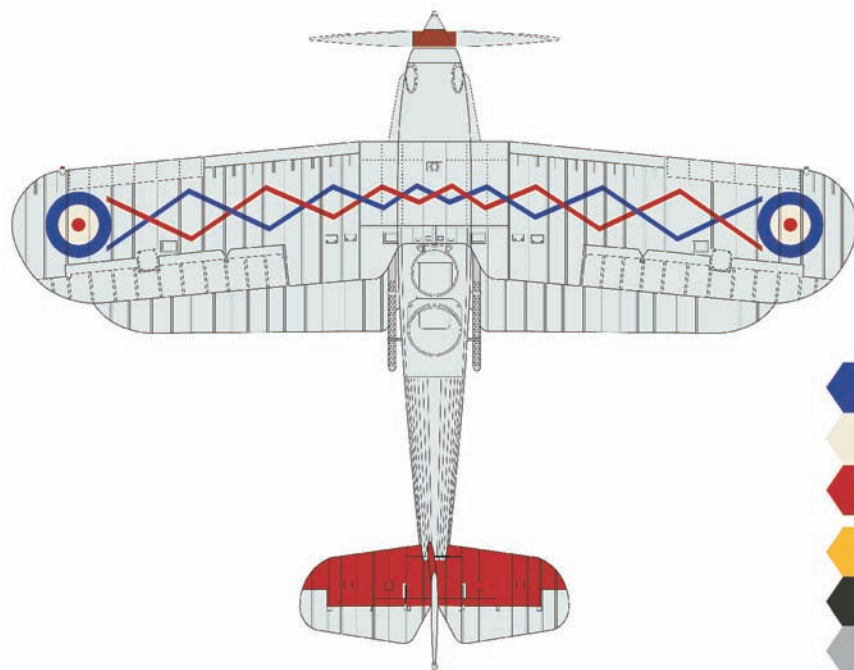

-  FS-15056
-  FS-37778
-  FS-11136
-  FS-33538
-  FS-17038
-  FS-17178

Hawker Demon, K4520
64 Squadron
Martlesham Heath, June 1937



The resin cast made by
HK Resin Model Henryk Kurowski
www.resinmodel.pl

© Silver Wings 2013