

**Silver Wings**  
**Wojciech Kułakowski**

30-680 Kraków  
ul.Serbska 2/15  
Poland  
www.silverwings.pl  
silverwings@silverwings.pl



High quality resin model kit

**Heinkel He-51 B-2**

Kat.No 32-002

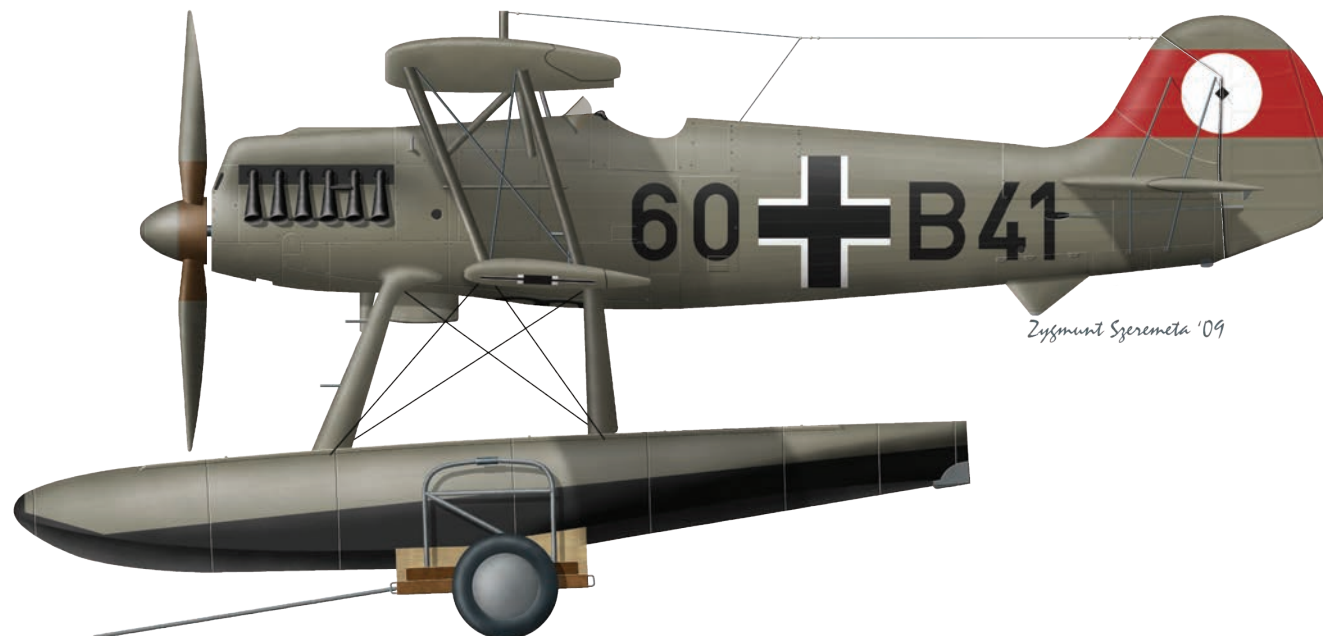

**Heinkel He 51 B-2**

Heinkel He-51 was development of the earlier He-49. It was produced in three main versions: fighter, ground attack and seaplane. The He-51 was a conventional biplane fighter, with all-metal construction and fabric covering. First prototype, the He-49a, flew in November 1932. With longer fuselage and better engine it was ordered into production as the Heinkel He-51 for Luftwaffe in May 1933. It was first used during Spanish Civil War in 1936. It was successful during operations against older biplane designs such as: Nieuport 52, Breguet 19, Potez 54. This time of superiority was short lived, with the arrival of large numbers of modern aircraft from the Soviet Union, including Polikarpov I-15 and I-16. After that the He-51 was withdrawn from fighter duty and relegated to the ground attack role by both the Legion Condor and the Spanish Nationalists. The He-51 B-2 (38 were built) was a float-plane fighter version equipped for catapult launching, but sometimes had racks for up to six 10kg bombs.

**TECHNICAL DATA**

**Length** -10,45 m , **Span** - 11,00 m

**Power plant** - BMW VI 7.3Z V12 engine, 560 kW (750 hp)

**Armament** - 2x M.G17 7,9 mm

**Max speed** - 318 km/h , **Range** - 500 km

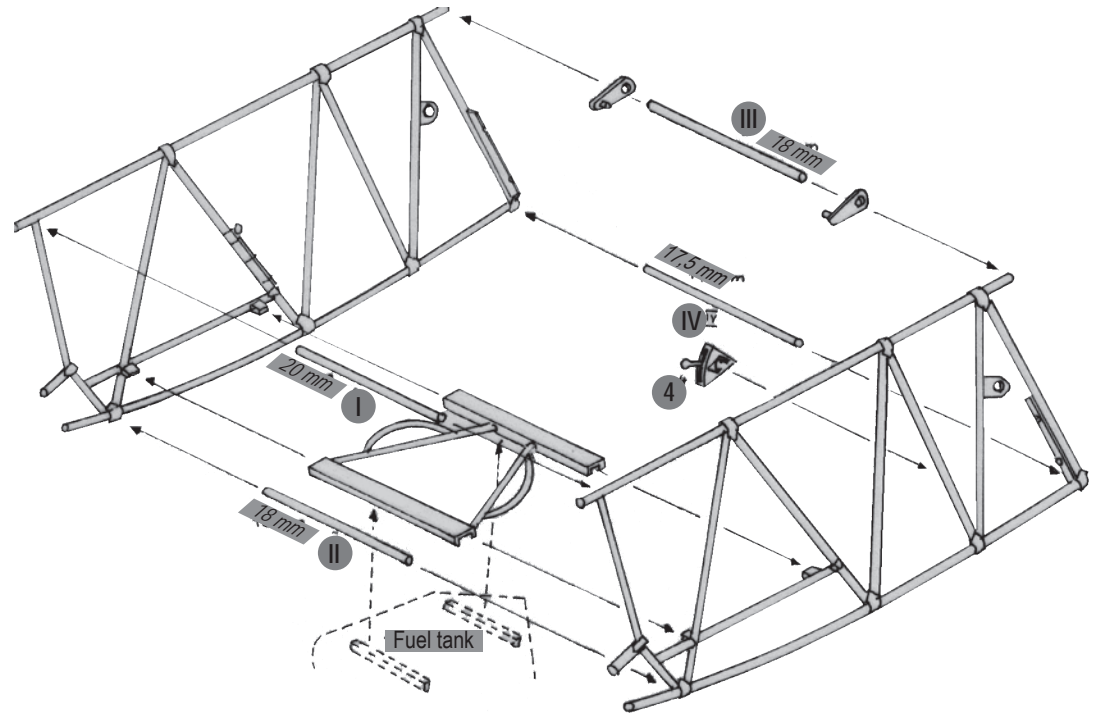
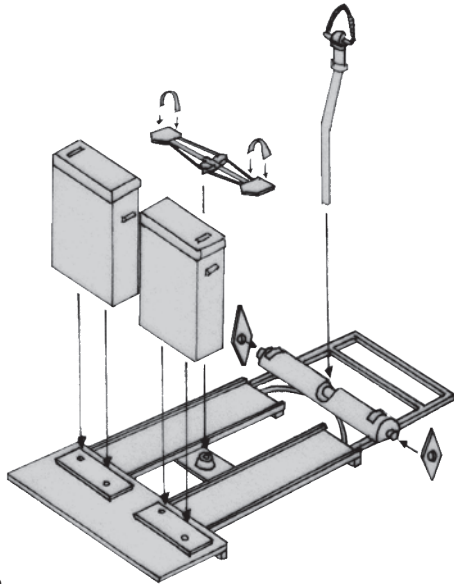
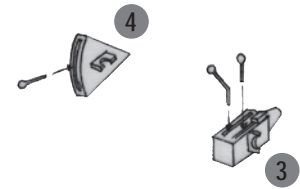
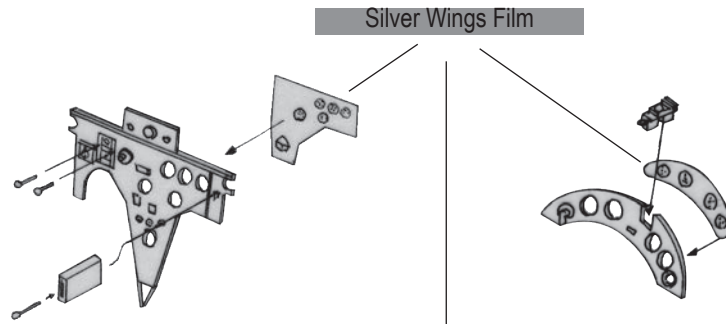
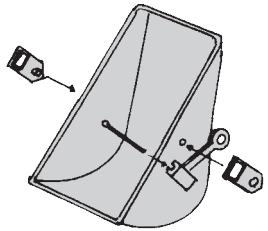

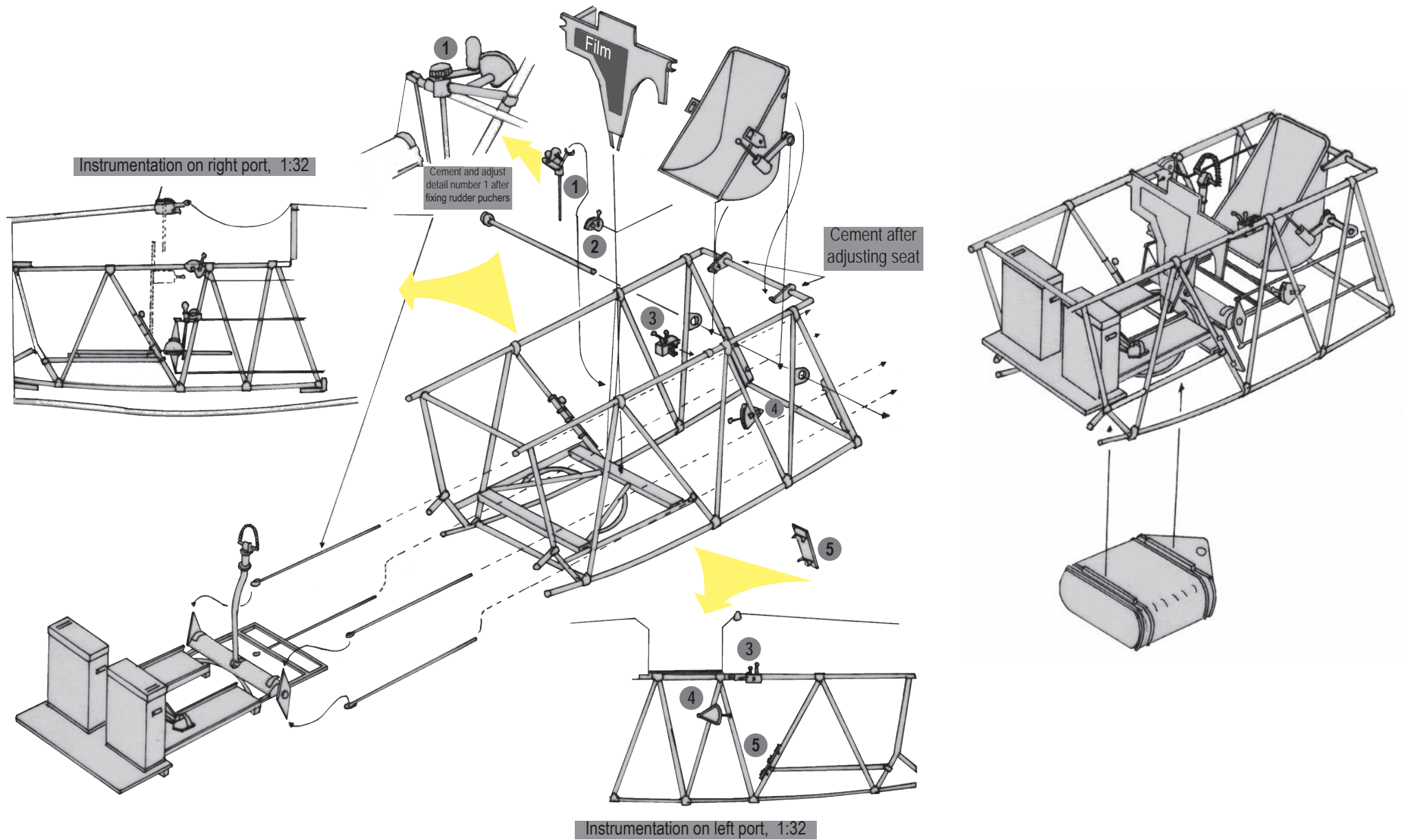

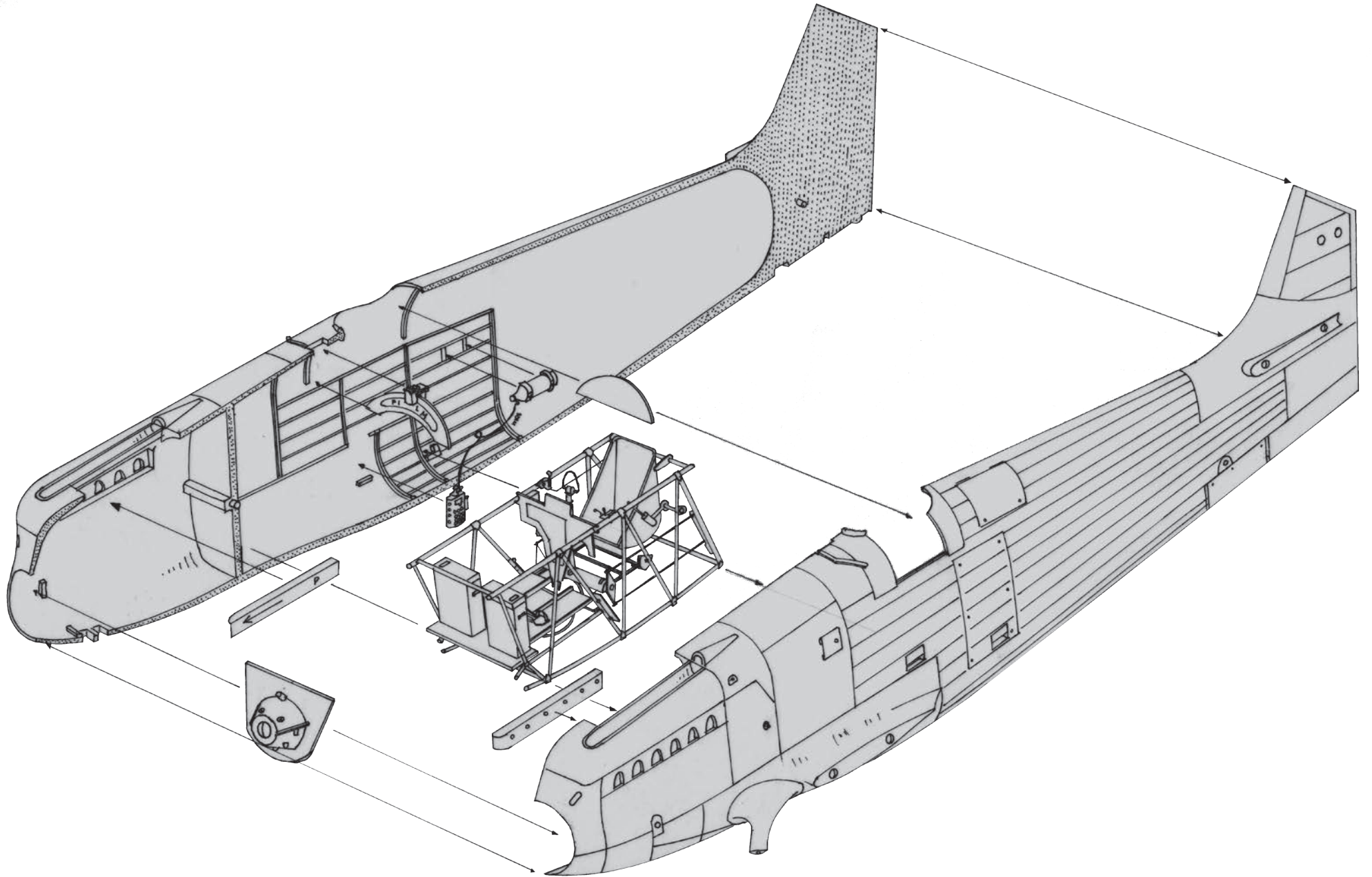



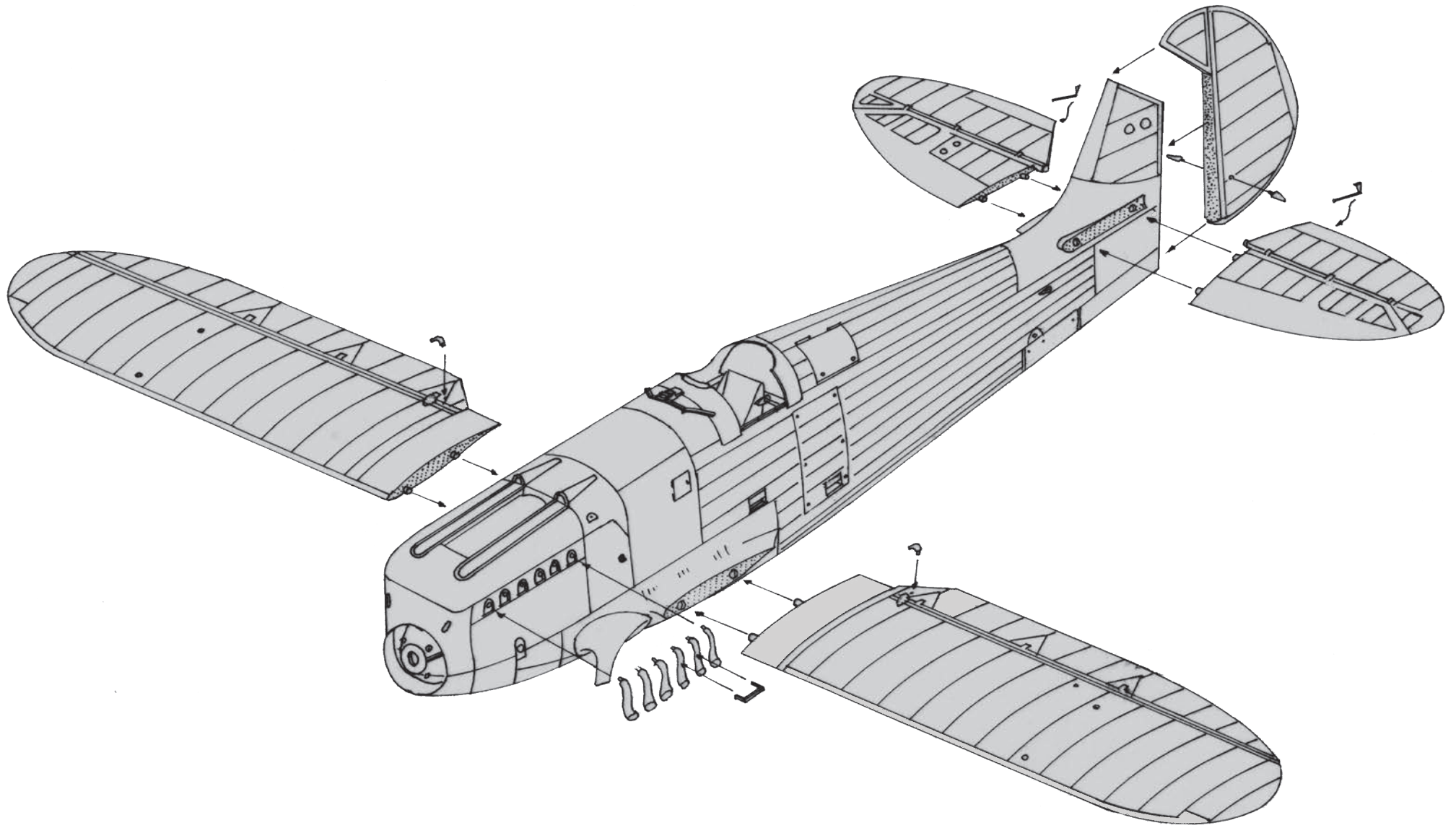

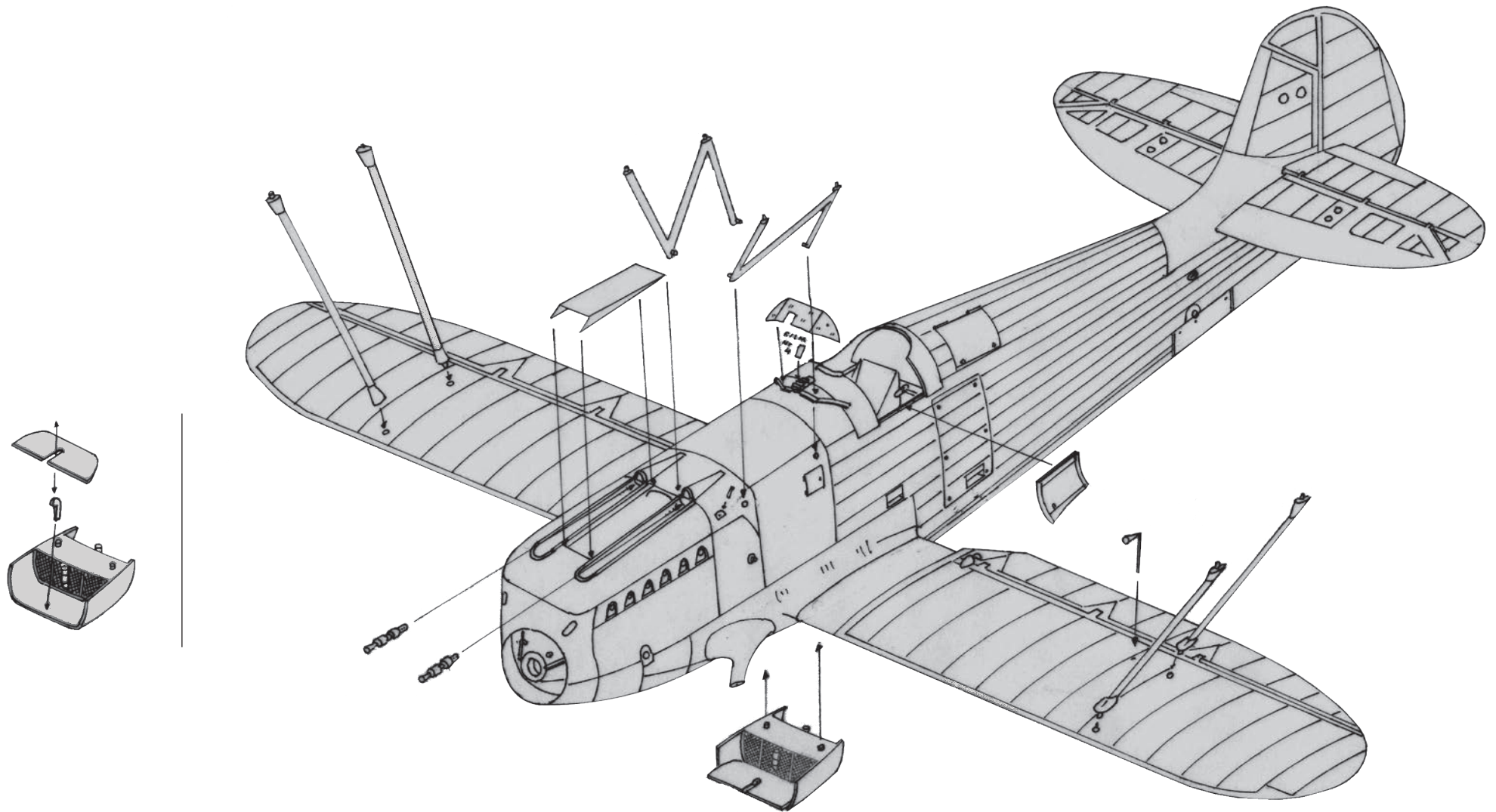

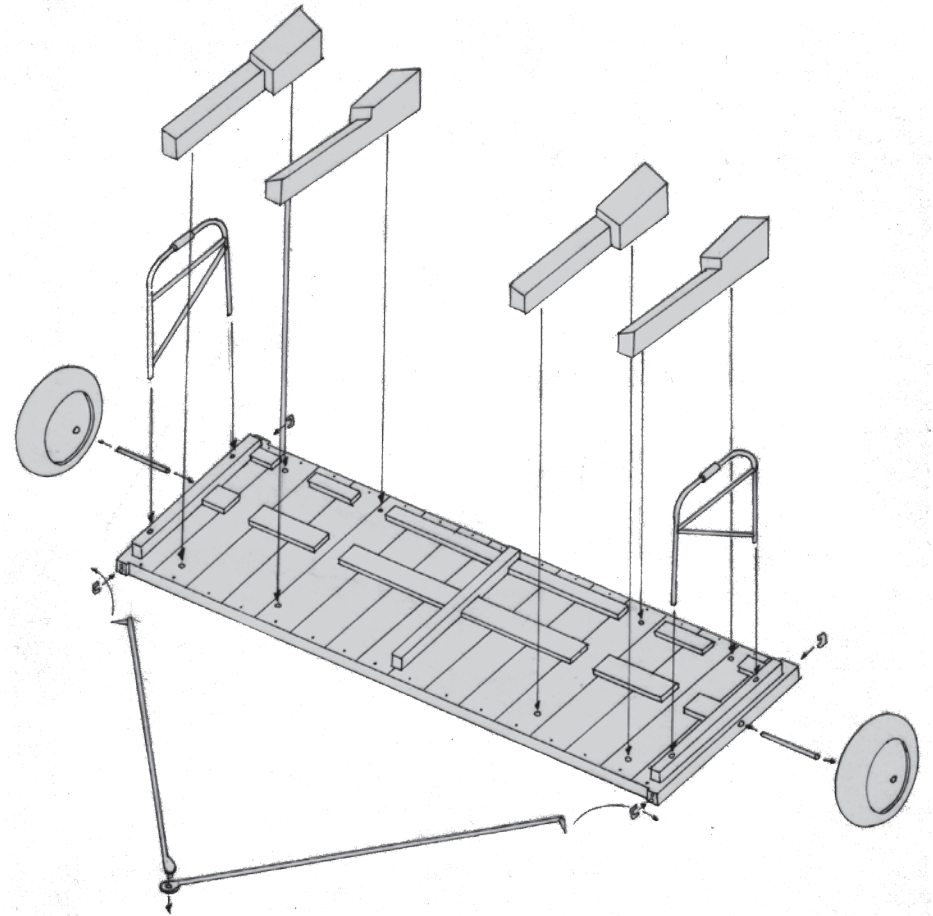
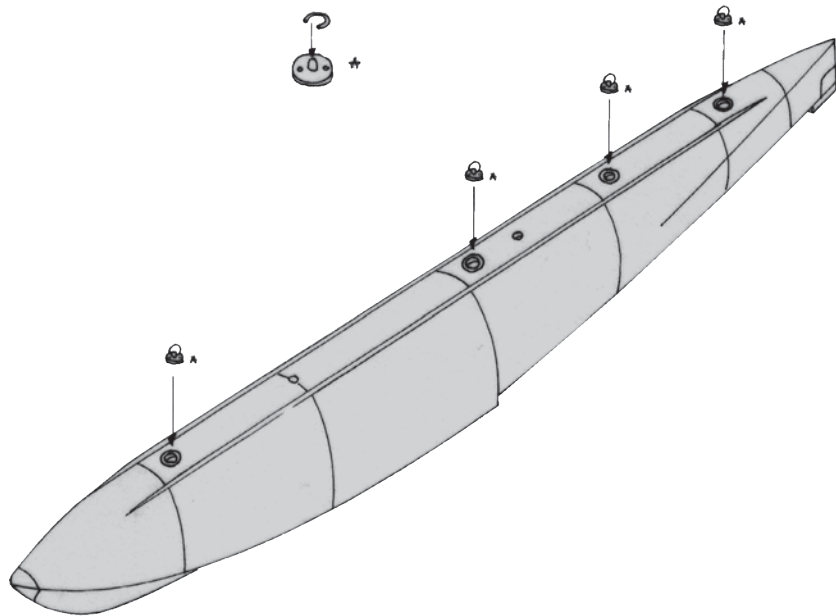
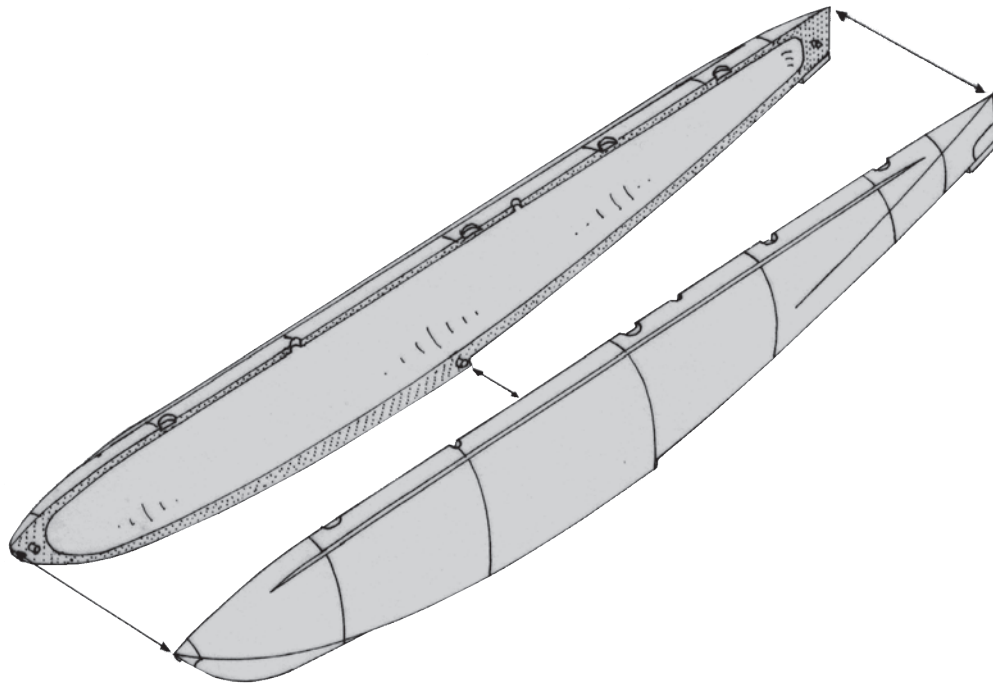

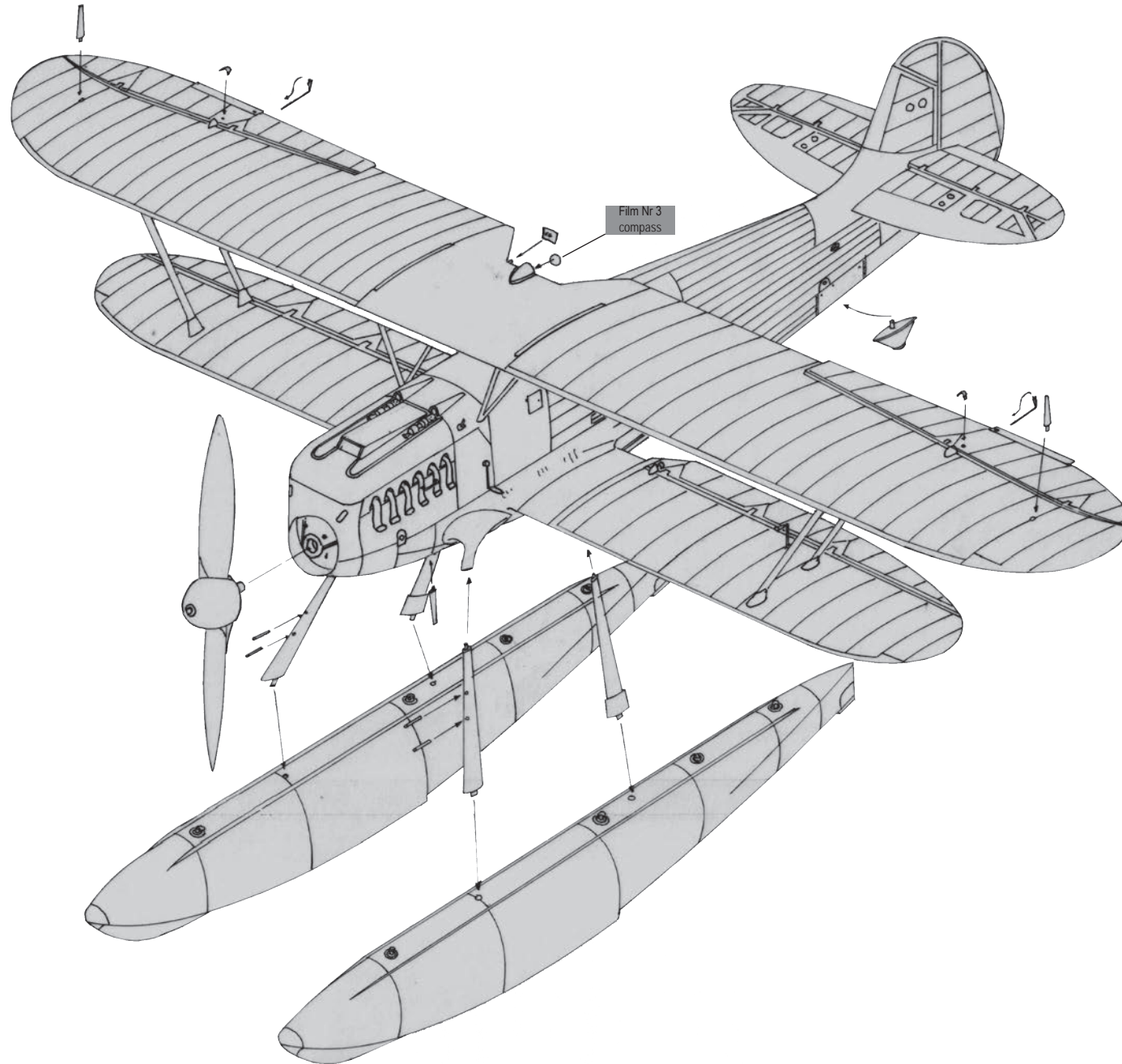



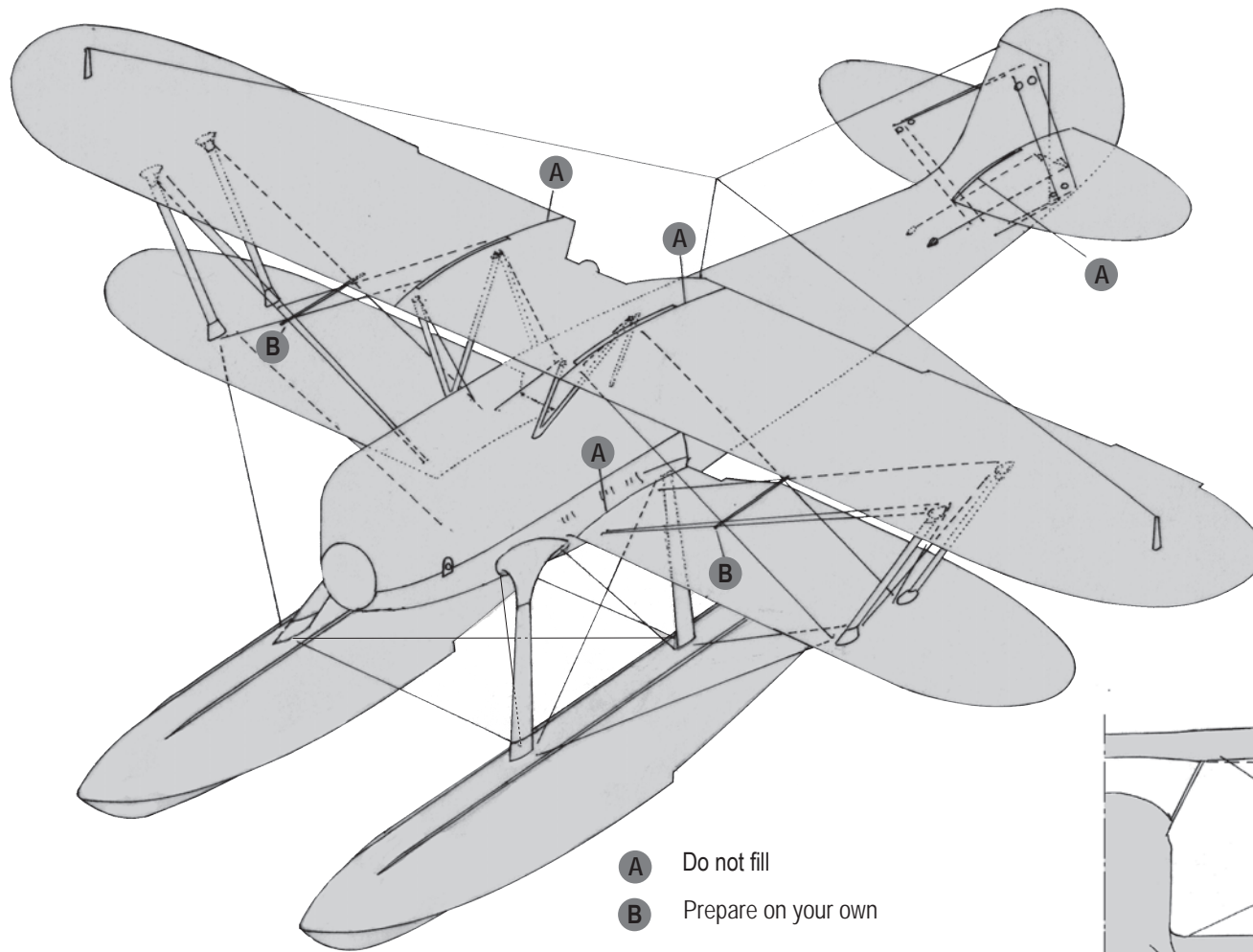

- A** Do not fill
- B** Prepare on your own

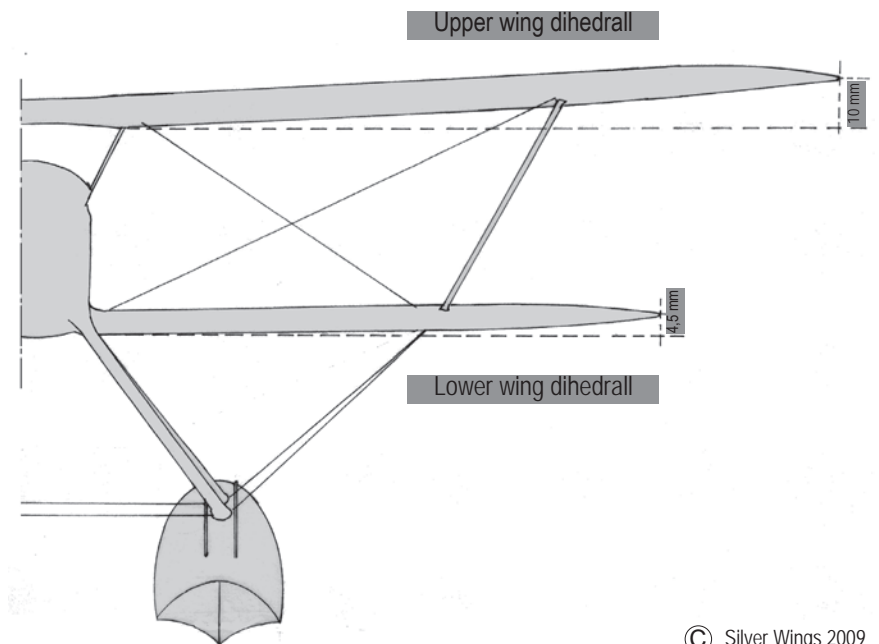

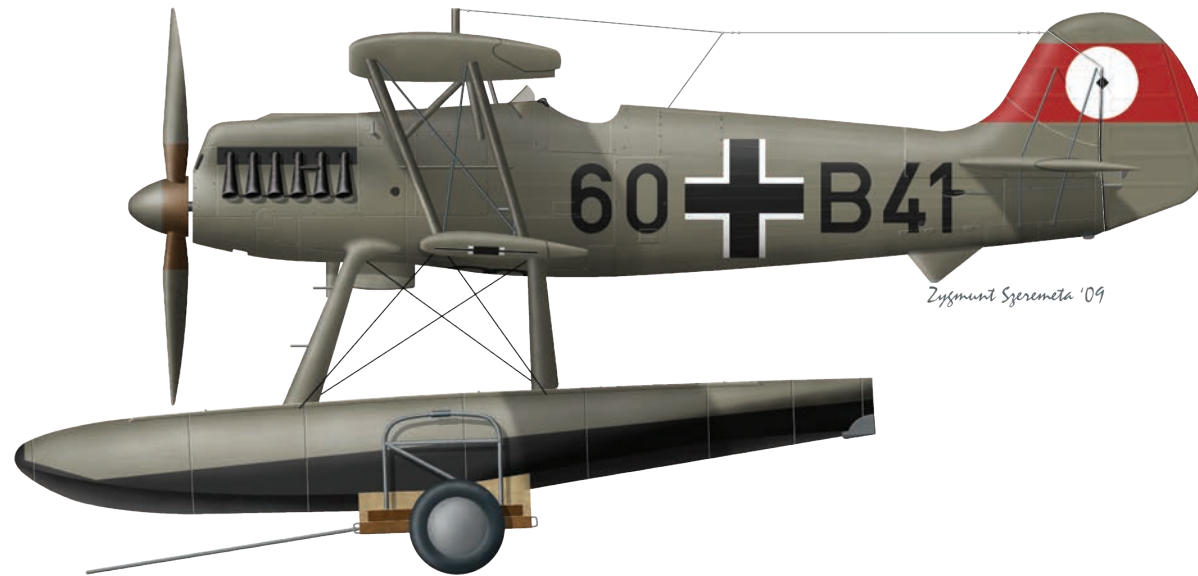

He-51 B-2 60+B 41  
of 1./Küstenjagdegeschwader 136 (1./Kü.J.Gr 136)  
Cruiser *Leipzig*, late 1936

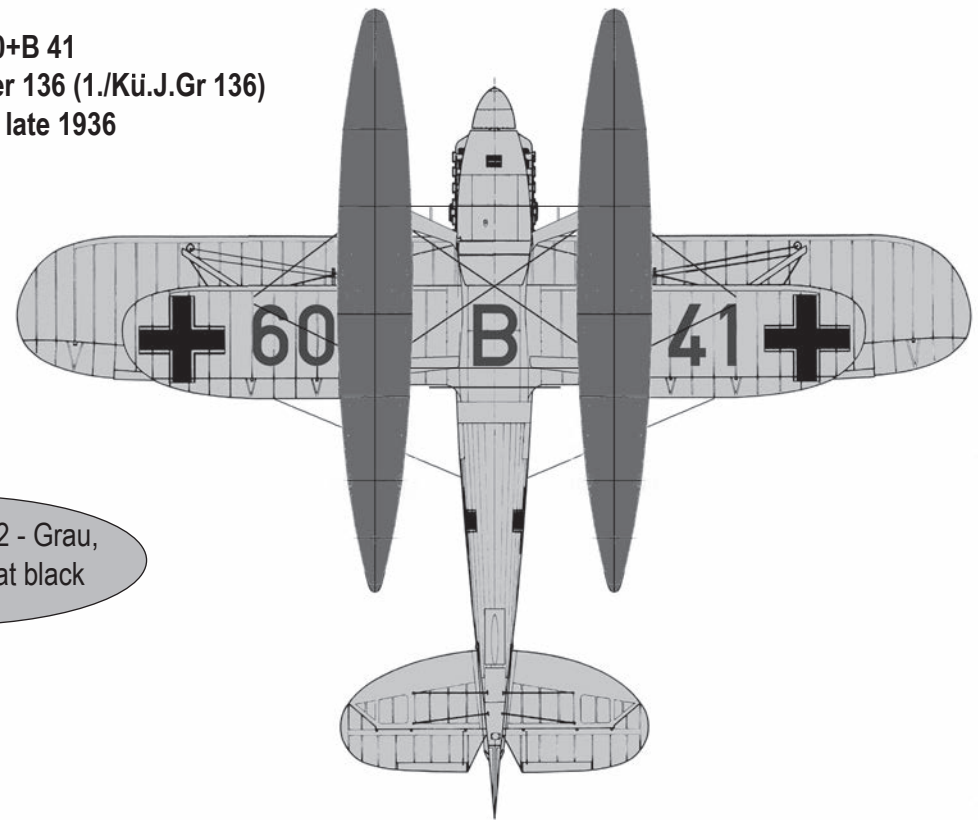
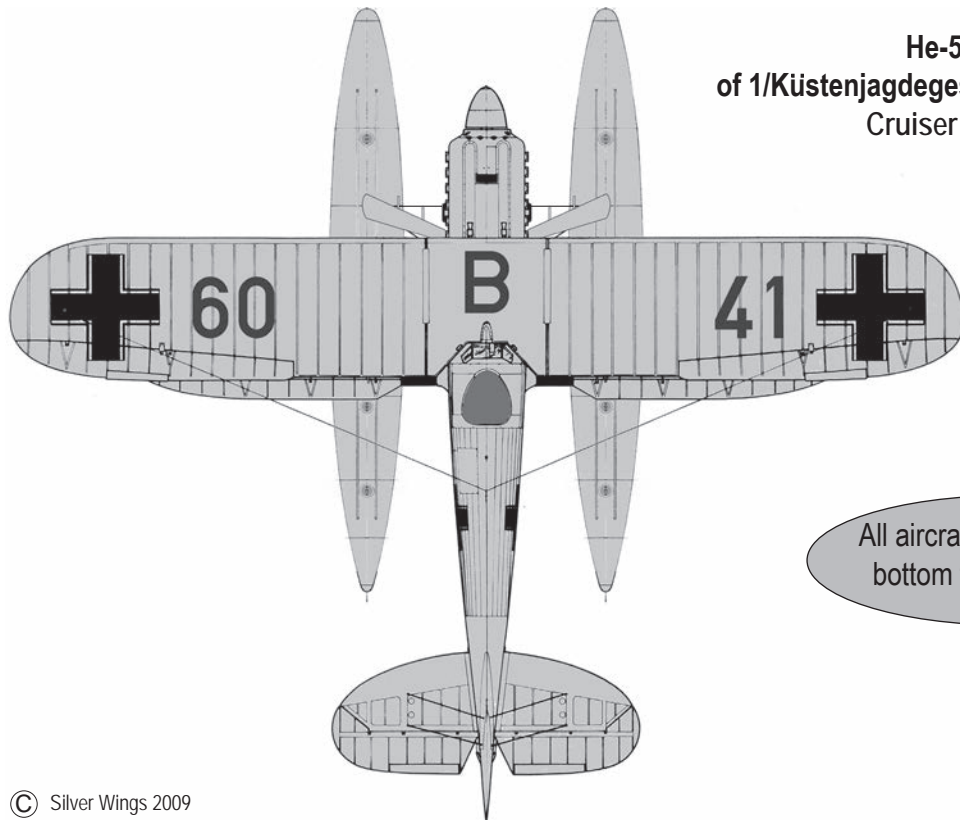

All aircraft RLM 02 - Grau,  
bottom floats - flat black