

Silver Wings
Wojciech Kułakowski
30-680 Kraków
ul. Serbska 2/15
Poland
www.silverwings.pl
silverwings@silverwings.pl



High quality resin model kit

Heinkel HE 51

Kat. No 32-001

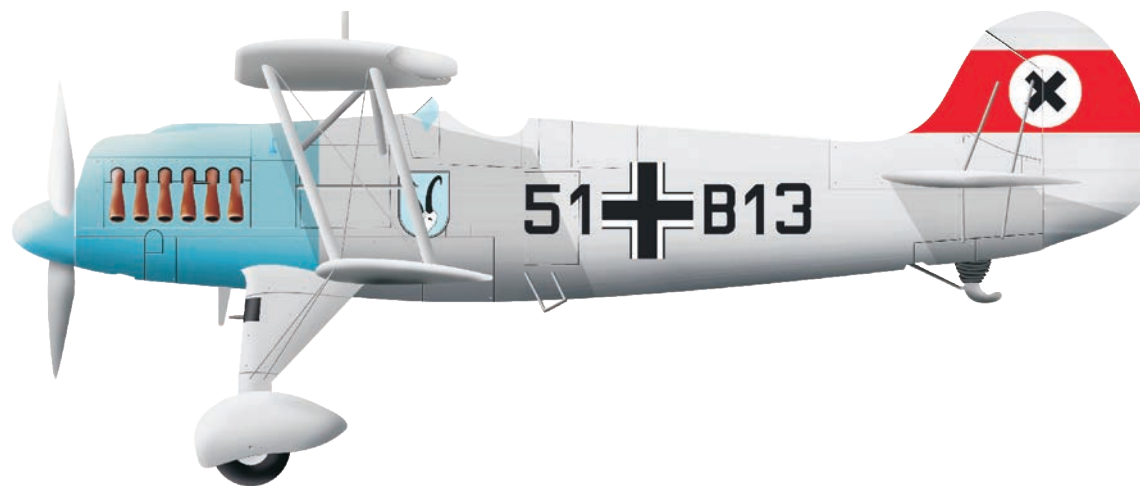

Heinkel HE 51

Heinkel He-51 was development of the earlier HE-49. It was produced in three main versions: fighter, ground-attack version and seaplane. The He-51 was a conventional biplane fighter, with all-metal construction and fabric covering. First prototype, the He-49a, flew in November 1932. With longer fuselage and better engine it was ordered into production as the Heinkel He-51 for Luftwaffe in May 1933. It was first used during Spanish Civil War in 1936. It was successful during operations against older biplane designs such as: Nieuport Ni-52, Brequet 19, Potez 54. This time of superiority was short lived, with the arrival of large numbers of modern aircraft from the Soviet Union, including Polikarpov I-15 and I-16.

After that the He-51 was withdrawn from fighter duty and relegated to the ground attack role by both the Legion Condor and the Spanish Nationalists. While a failure as a fighter, the Heinkel proved successful as a ground attack aircraft, being used by the Luftwaffe in World War II.

The HE-51 aircrafts were in use in front line service until 1938.

Technical data

Length - 8,40m

Span - 11,00m

Power plant - 1x BMW VI 7.3Z V12 engine, 560kW (750hp)

Armament - 2 M.G.17 7,9mm + 6x10kg of bomb load (C1)

Max speed - 330km/h

Range - 570km

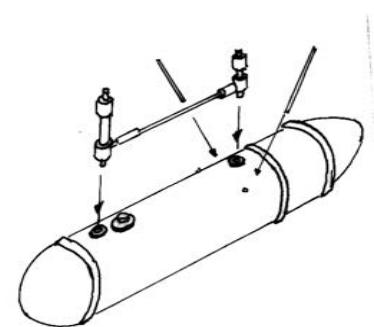
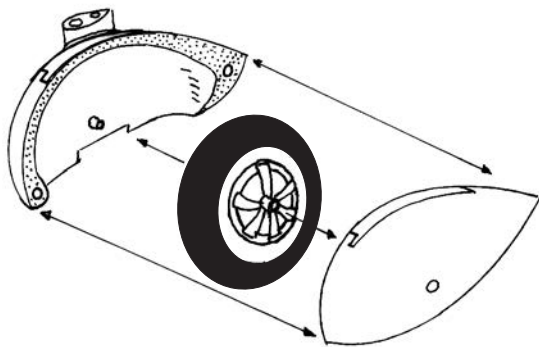
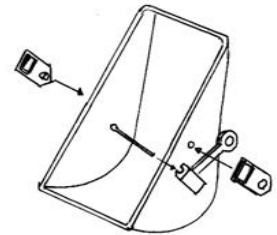
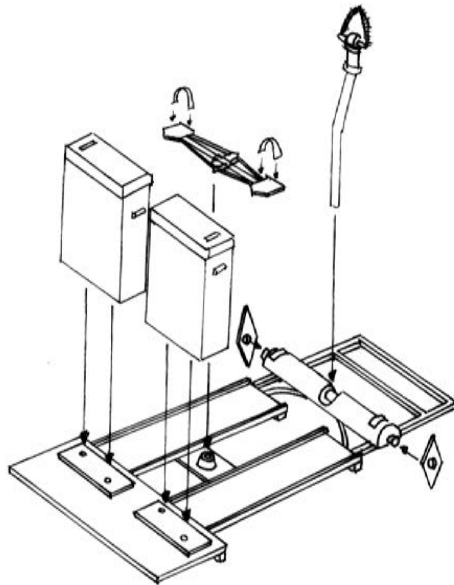
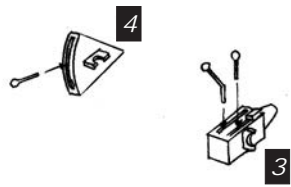
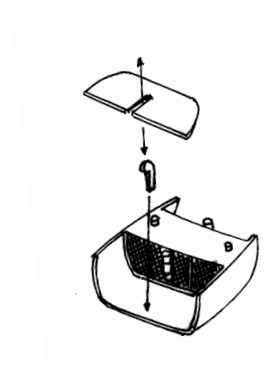
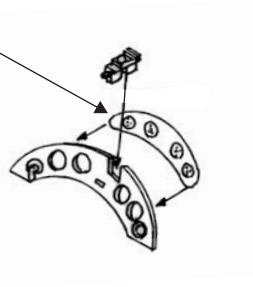
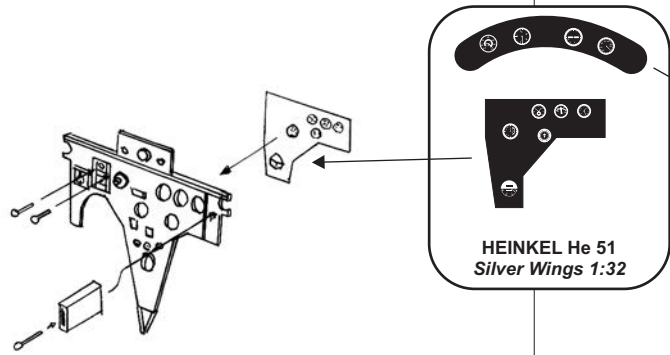

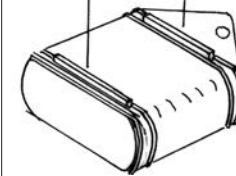
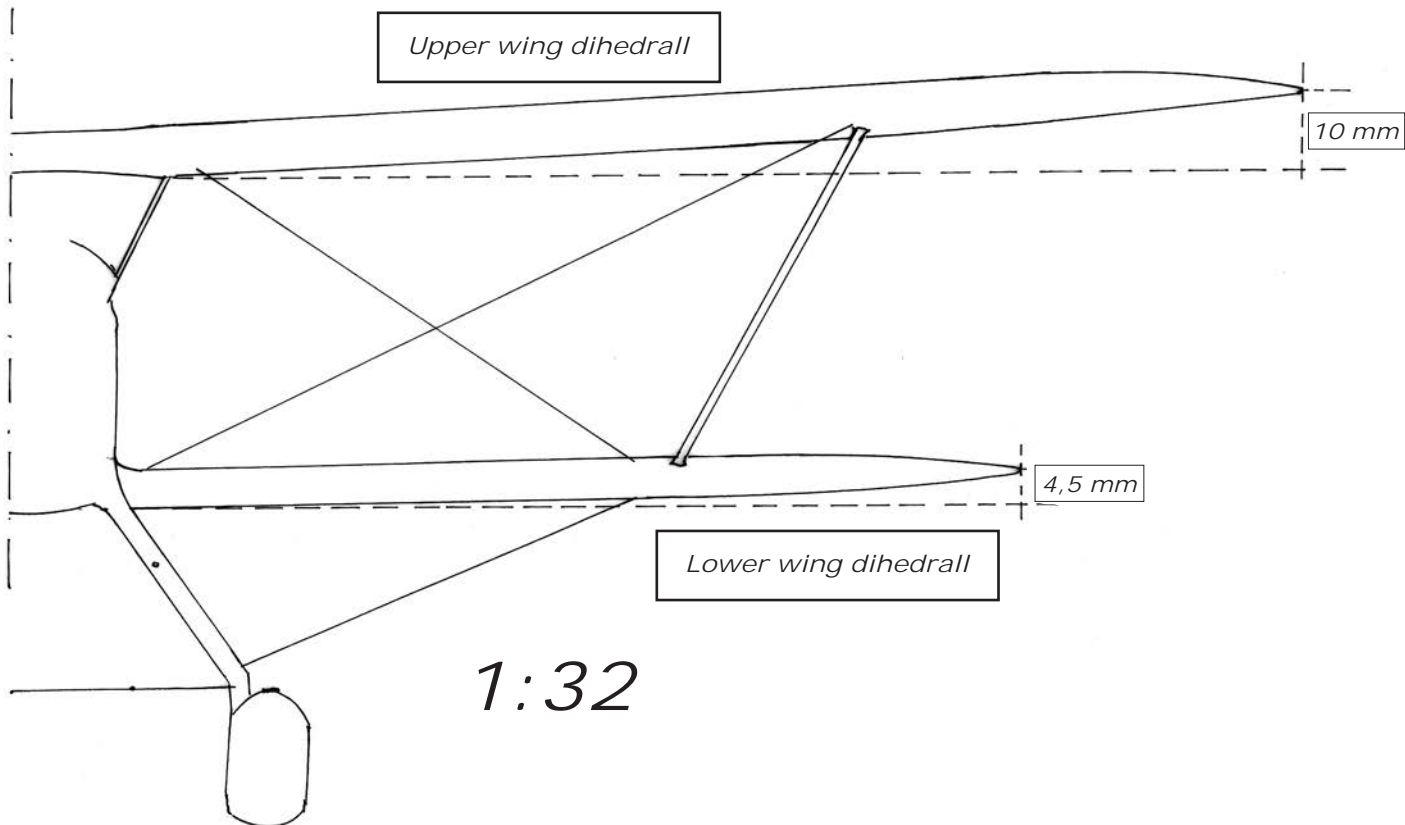
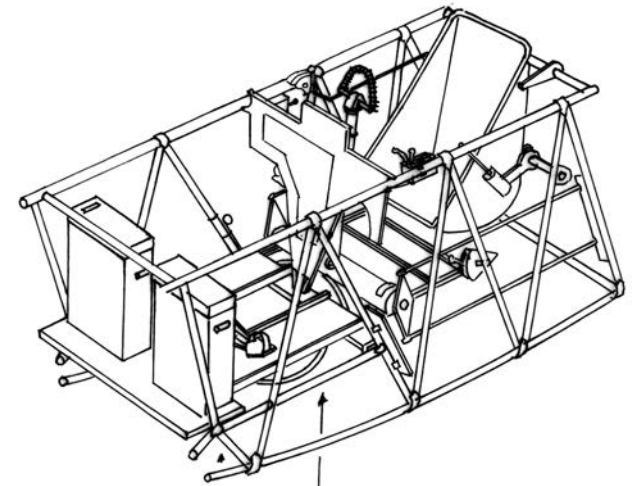
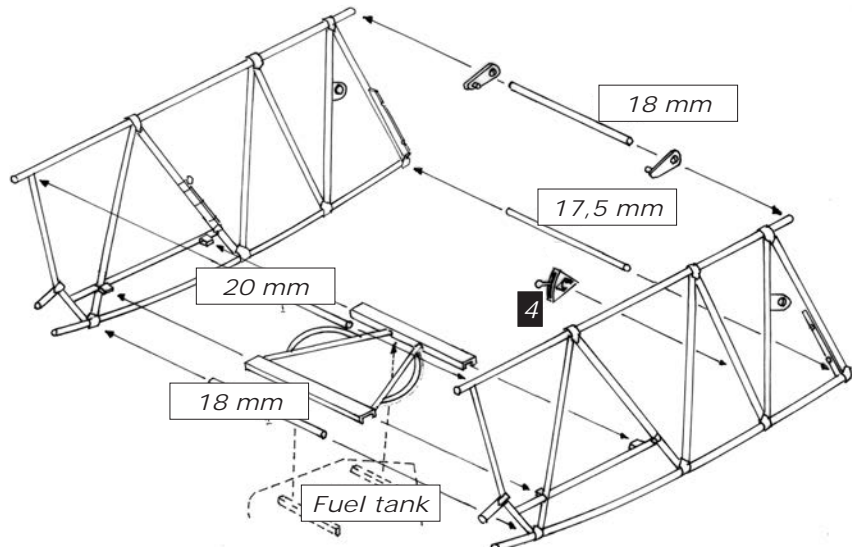

Instrumentation on right port, 1:32

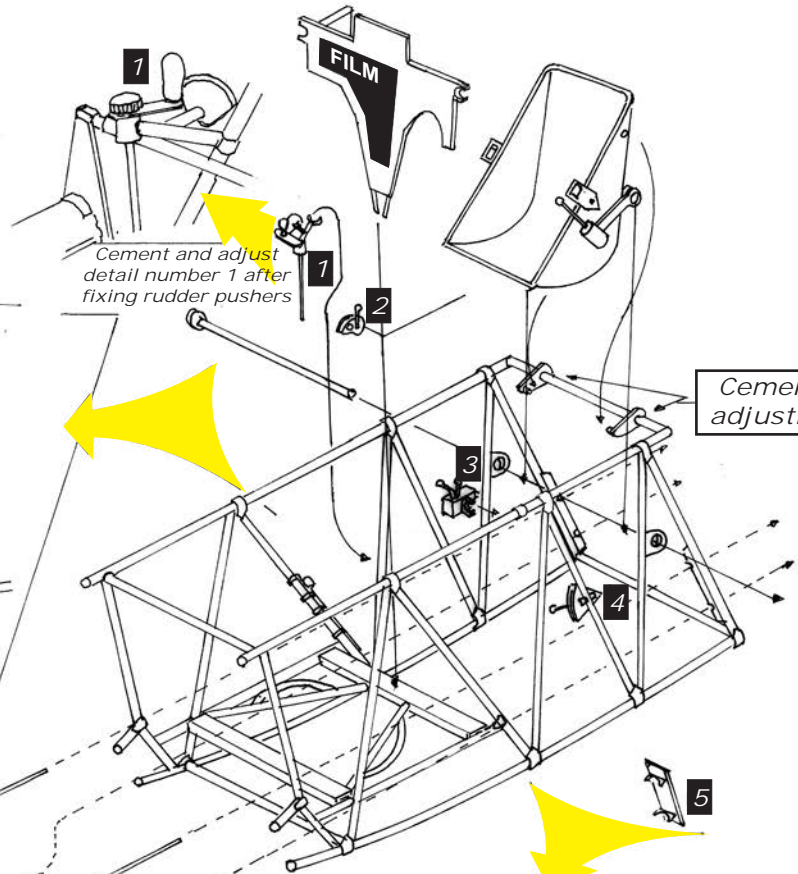
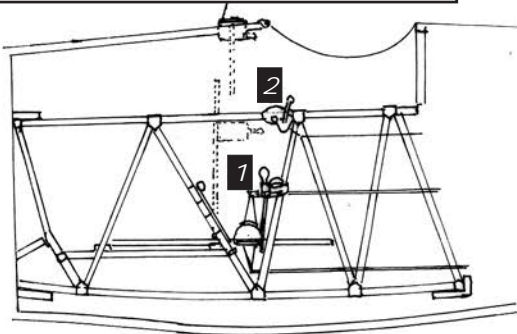

Cement after adjusting seat

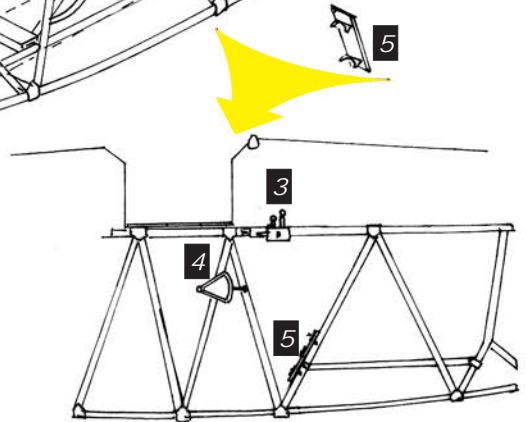
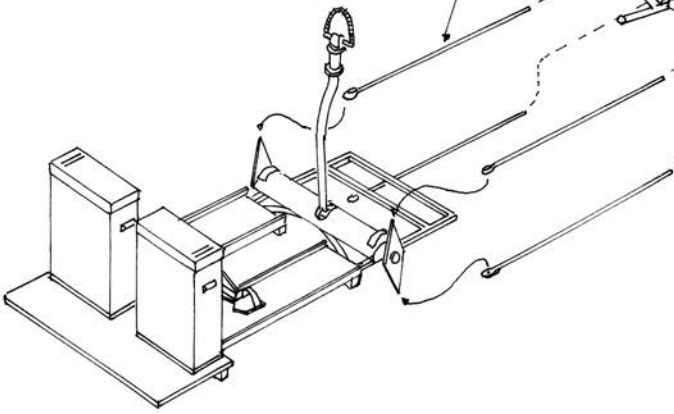

Instrumentation on left port, 1:32

UWAGA

NOTICE

1. Wszystkie odkształcone części można przywrócić do pierwotnego kształtu po uprzednim zanurzeniu ich we wrzącej wodzie.
2. Do montażu używać klejów cyjanoakrylowych.

1. All deformed parts should be easy reshaped after dipping them for a few seconds into a boiling water.
2. Use cyanoacrylate glue.

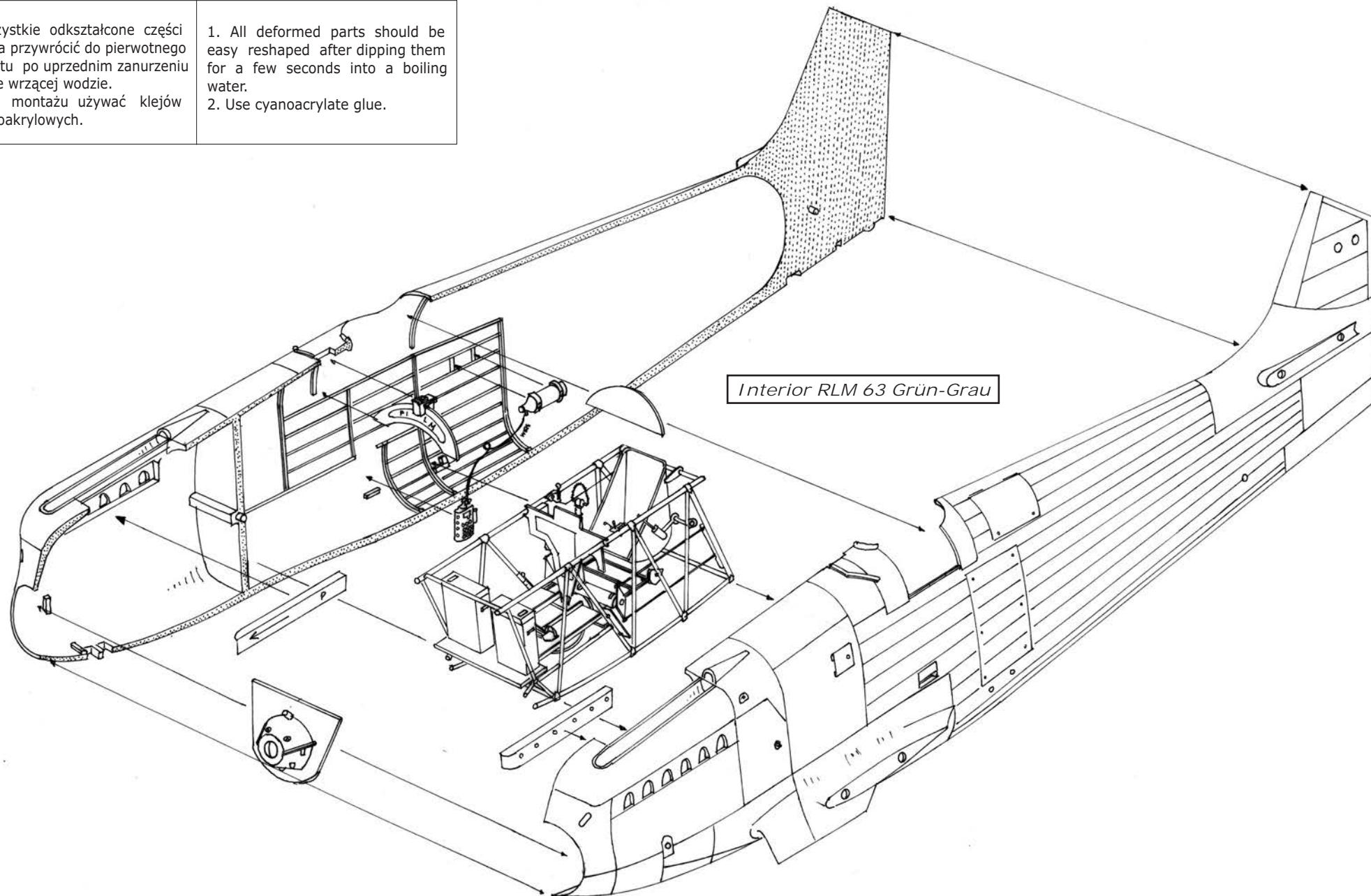

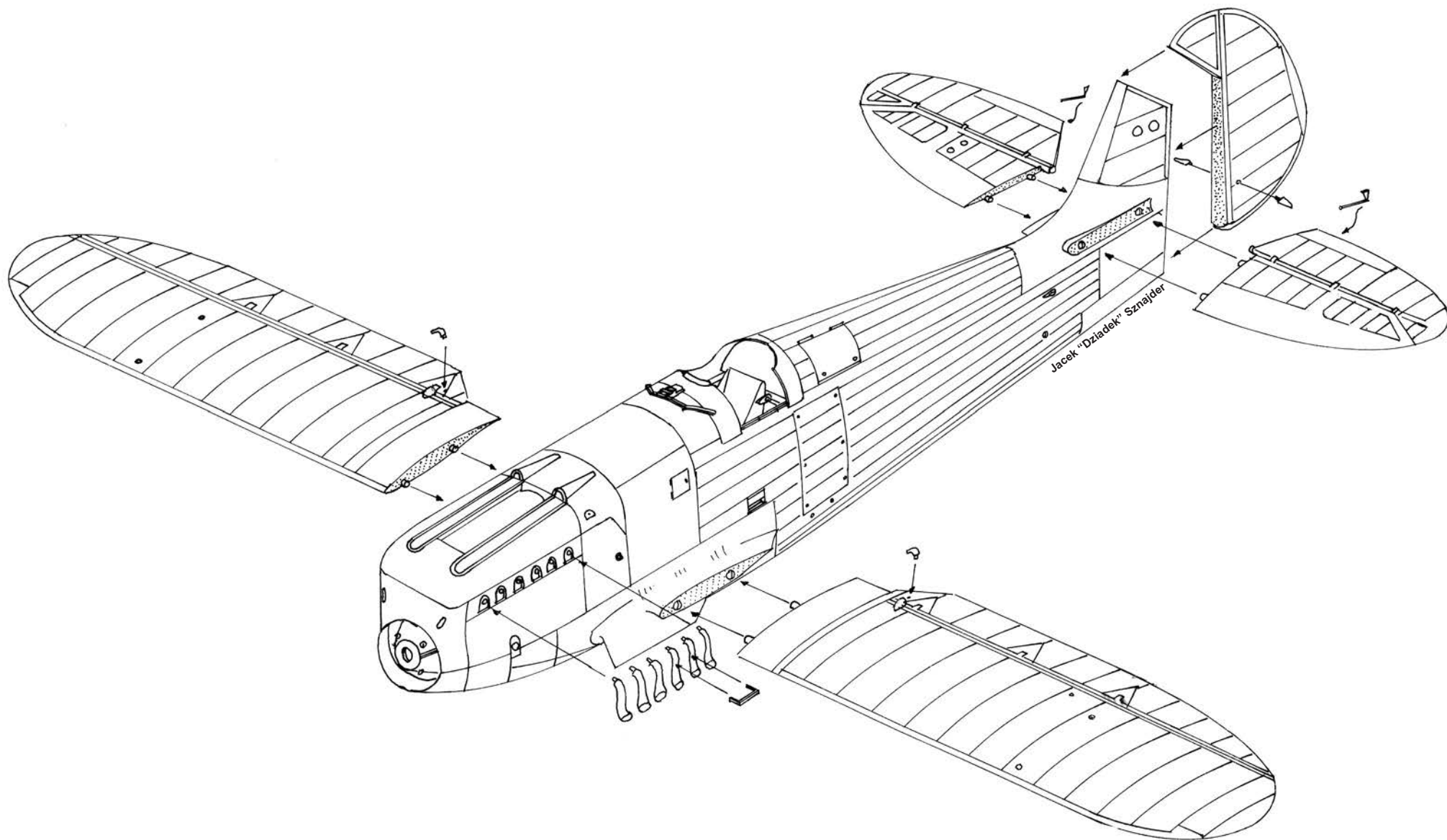

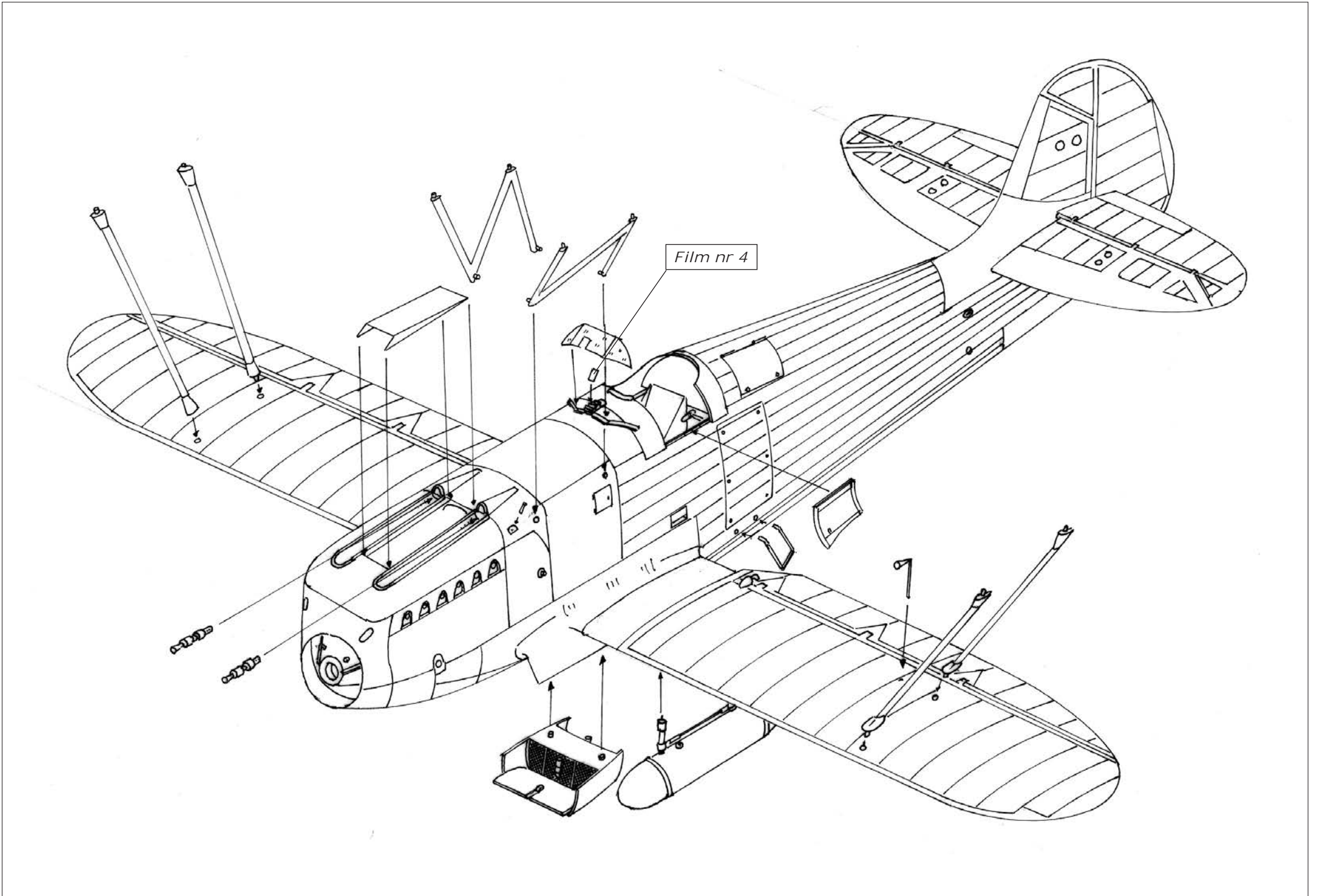

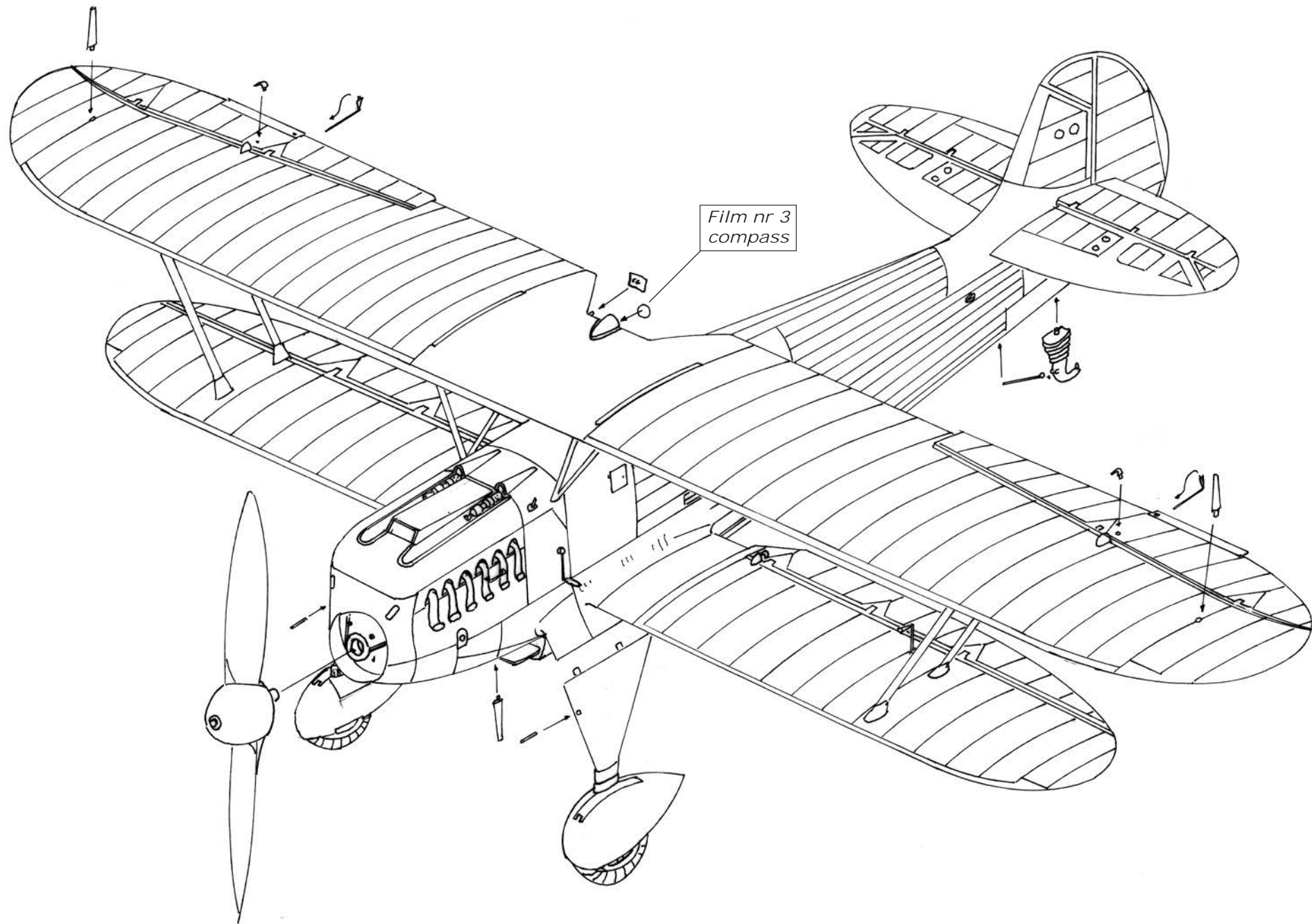

Film nr 3
compass

Heinkel He 51
(rigging scheme)

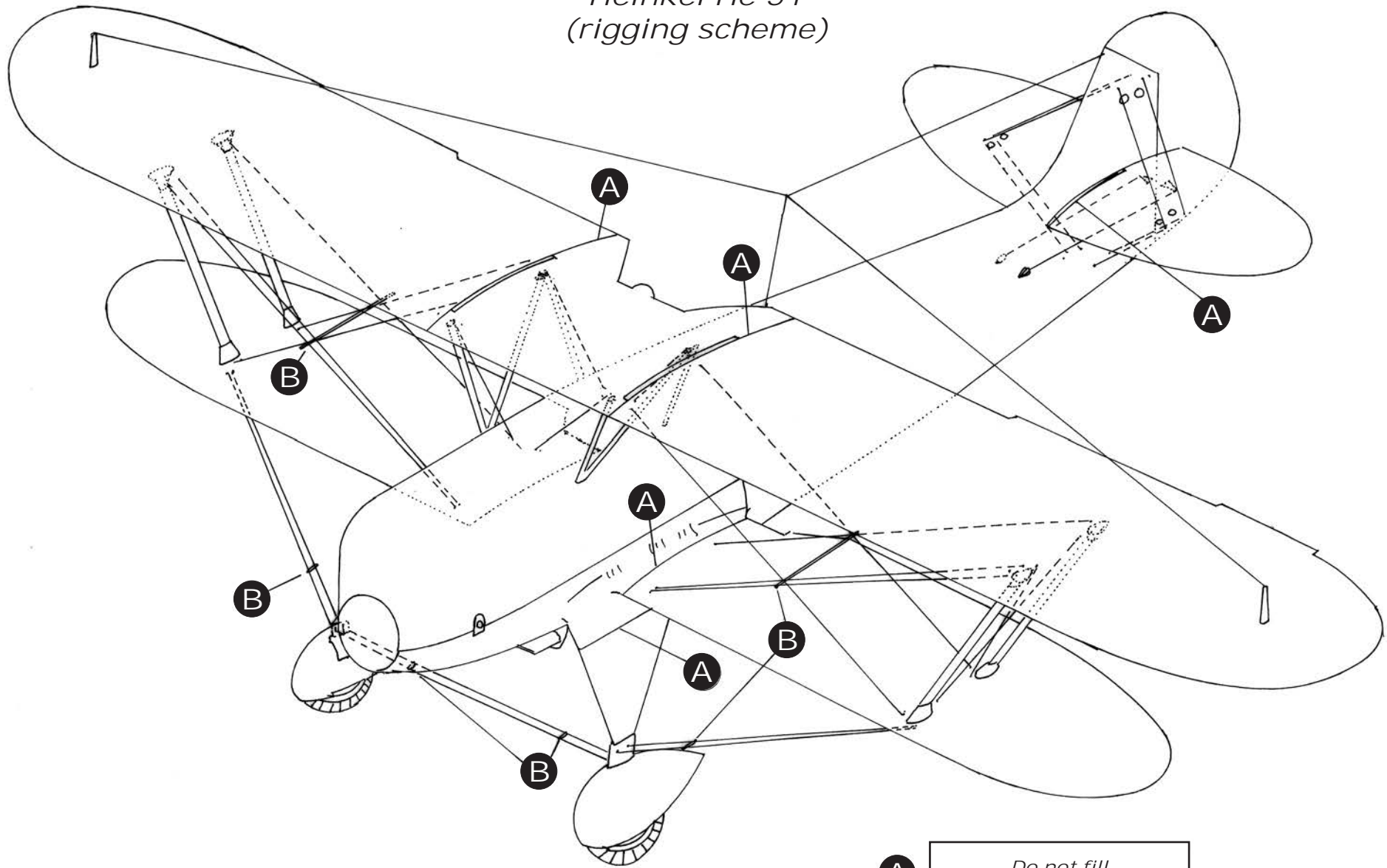

- | | |
|---|---------------------|
| A | Do not fill |
| B | Prepare on your own |

Bavarian Blue



He51A of 3.Staffel of JG 223
at Wien-Aspern, autumn 1938

RLM 63 Grün-Grau

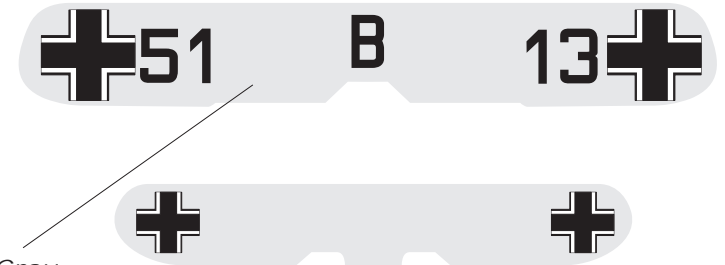

White

RLM 63 Grün-Grau

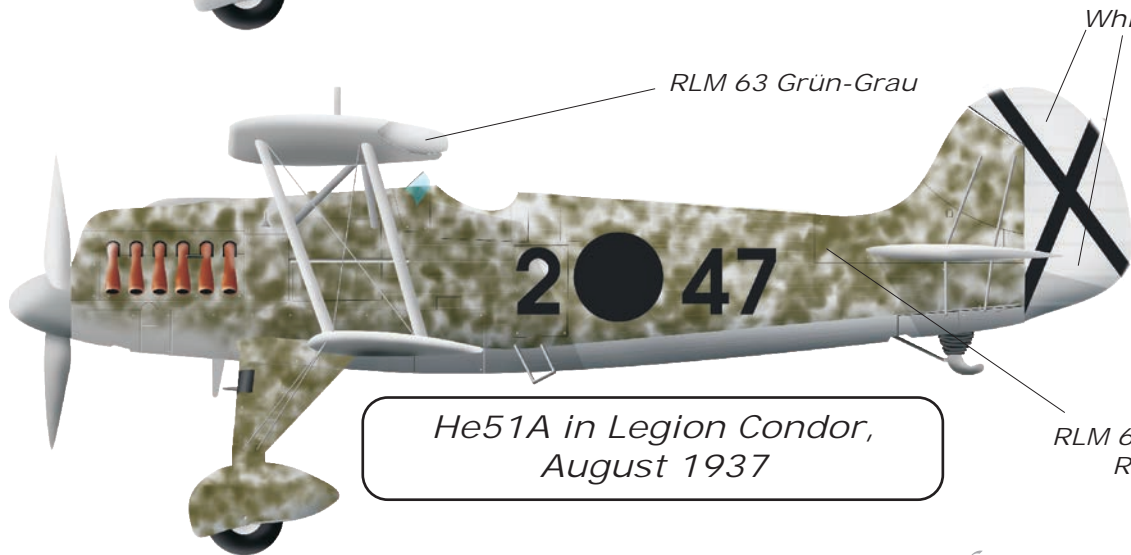

He51A in Legion Condor,
August 1937

RLM 61 Dunkel-Braun
RLM 62 Grün

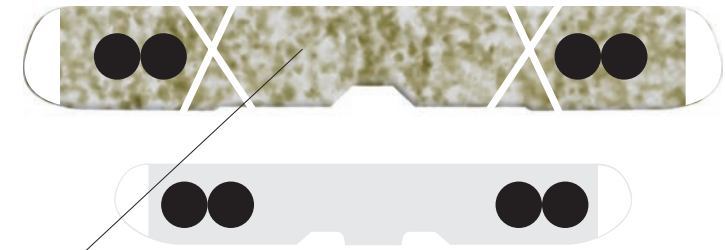

Silver Wings
Wojciech Kułakowski
30-680 Kraków
ul. Serbska 2/15
Poland
www.silverwings.pl
silverwings@silverwings.pl